

Model OI-675 Electrochemical Sensor Assembly



Operation Manual

Revision 1.7

Product Overview

The Otis Instruments, Inc. Model OI-675 Electrochemical Sensor Assembly is a versatile system with the ability to detect of a variety of gases.

The OI-675 Electrochemical Sensor Assembly's key feature is non-intrusive calibration. With all adjustments made at the sensor assembly, one-man non-intrusive calibration is quick, easy, and allows the device to remain Class I, Division 1, Groups C and D certified while in the field. Non-intrusive calibration is made possible by using an Otis Instruments, Inc. distributed magnet to activate the *MENU*, *ADD* and *SUB* buttons.

The OI-675 incorporates any “4” Series Electrochemical Sensor and the OI-352 two-wire loop (4 to 20mA output) Amplifier Card.

An extended life-expectancy, paired with the ability to withstand extreme climatic conditions and harsh environments, make the OI-675 Electrochemical Sensor Assembly a flexible and dependable safety tool for gas detection.



Table of Contents

Product Overview	3
Introduction	6
4-20mA Current Loop Introduction	7
<i>Overview</i>	7
<i>Calculations</i>	7
<i>Measuring Current</i>	8
Warnings	9
Complete System Diagrams	10
<i>OI-675 Complete System w/ Rainguard</i>	10
<i>Front Panel</i>	11
Wiring Configurations	12
<i>Sensor Assembly to Monitor Connection</i>	12
<i>Power Supply Configuration</i>	14
<i>Power On</i>	15
Calibration	16
<i>Change/Check Null</i>	17
<i>Setting Calibration</i>	18
Sensor Replacement	21
Specifications	23

Introduction

This document is an Operation Manual containing diagrams and step-by-step instruction for proper operation of the Otis Instruments, Inc. Model OI-675 Electrochemical Sensor Assembly. This document should be read before initial operation of the product.

Should a question arise during the use of the product, this document will serve as a first reference for consultation. If further questions arise, or if the device is not working properly, please contact the sales representative of this product.

4-20mA Current Loop Introduction

This is just a brief overview of 4-20mA—this overview should not be considered a complete reference for proper implementation or use. Prior knowledge of industry standards pertaining to 4-20mA specifically, and other aspects of electronics, are assumed to be known by the technician. For proper connection to a monitor or PLC, refer to the manufacturer's specific manual or instructions for that particular piece of hardware.

Overview

4-20mA ("four to twenty"), is an analog electrical transmission standard used by Otis Instruments for some of its ambient gas sensors and monitors. The signal is a current loop where 4mA represents zero percent signal, and 20mA represents 100 percent signal (full scale of the sensor assembly). The relationship between the current loop and the gas value is linear.

The 4mA allows the receiving monitor/PLC to distinguish between a zero signal, a broken wire, or a dead instrument. Benefits of 4-20mA convention are that it is: an industry standard, low-cost to implement, can reject some forms of electrical noise, and the signal does not change value around the "loop" (as apposed to a voltage). Only one current level can be present at any time; each device which operates via 4-20mA must to wired directly to the monitoring device.

Calculations

$$I_{(4-20)} = \left(\frac{(16 \cdot \text{value})}{\text{scale}} \right) + 4$$

$I_{(4-20)}$: current of loop, measured in mA

value : PPM or %, of gas concentration

scale : full scale of sensor (see below for usual ranges)

Target Gas	Range	Temp.
H2S = Hydrogen Sulphide	0-100 ppm	-20 to 50C
O2 = Oxygen	0-25 %	-30 to 55C
SO2 = Sulfur Dioxide	0-20 ppm	-20 to 50C
CL2 = Chlorine	0-10 ppm	-20 to 50C
H2 = Hydrogen	0-4 %	-20 to 40C
NH3 = Ammonia	0-100 ppm	-40 to 40C
CO = Carbon Monoxide	0-999 ppm	-20 to 50C
F2 = Florine	0-1 ppm	-10 to 40C
HF = Hydrogen Fluoride	0-10 ppm	-10 to 40C
H2S-2 = Hydrogen Sulphide (extended temp)	0-100 ppm	-40 to 50C

Table – Gas Sensor Details

-more-

Calculations cont...

Actual ranges may vary with our product. If unsure, confirm with the actual gas sensor assembly distributor, Otis Instruments sales representative, or call the main Otis Instruments office for more details.

Measuring Current

If the value measured is 0mA, then: the loop wires are broken, the sensor assembly is not powered up, the sensor assembly is malfunctioning, or the monitor is malfunctioning. A DMM (digital multi meter) or Current Meter may be used to test a 4-20mA signal. Place the DMM or Current Meter in line with the loop and measure current. The DMM/Current Meter may be used in conjunction with the normal monitoring device.

Warnings

- ◆ The Otis Instruments OI-675 Electrochemical Sensor Assembly is Class I Division 1 Certified. The assembly is able to maintain its certification at all times while in the field, simply by using the non-intrusive calibration method which requires the use of an Otis Instruments, Inc. distributed magnet. However, if the Moore lid is removed, for whatever reason, the OI-675 Electrochemical Sensor Assembly's certification is no longer valid.
- ◆ To avoid invalidating the certification, complete all wiring configurations *BEFORE* putting the OI-675 Electrochemical Sensor Assembly in the field. Once in the field, always use the Otis Instruments, Inc. distributed magnet to ensure non-intrusive calibration.
- ◆ Strong magnetic fields may interfere with the non-intrusive magnetic switches. A strong magnetic field may momentarily active a switch, or permanently disable the switch to the “on” or “off” position.
- ◆ Do not cover the hole in the calibration cup, as this will cause the calibration to be inaccurate.

Complete System Diagrams

The following diagrams should be consulted for identification of the system and all parts that may be referred to in this Operation Manual.

OI-675 Complete System w/ Rainguard

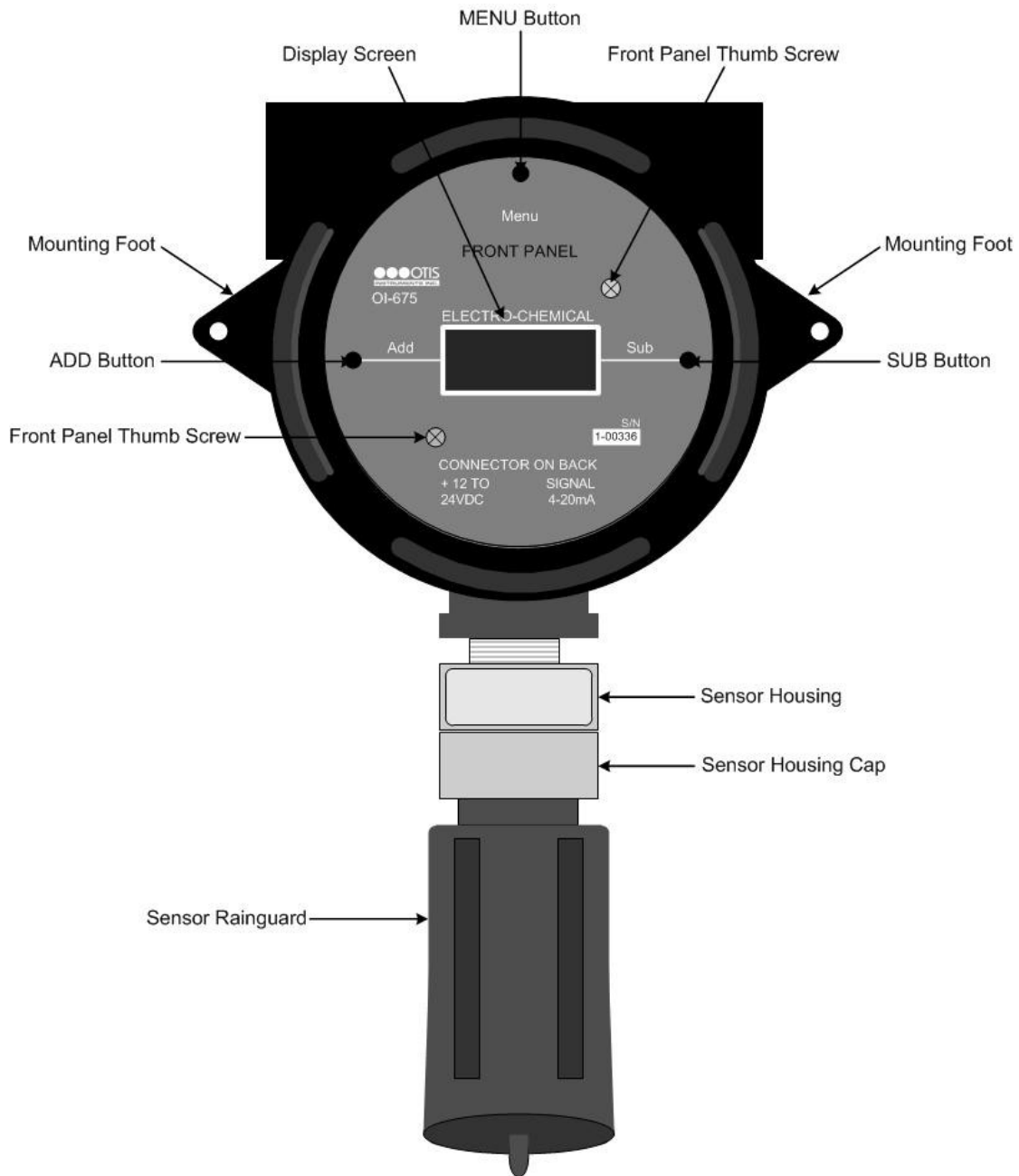

Front Panel

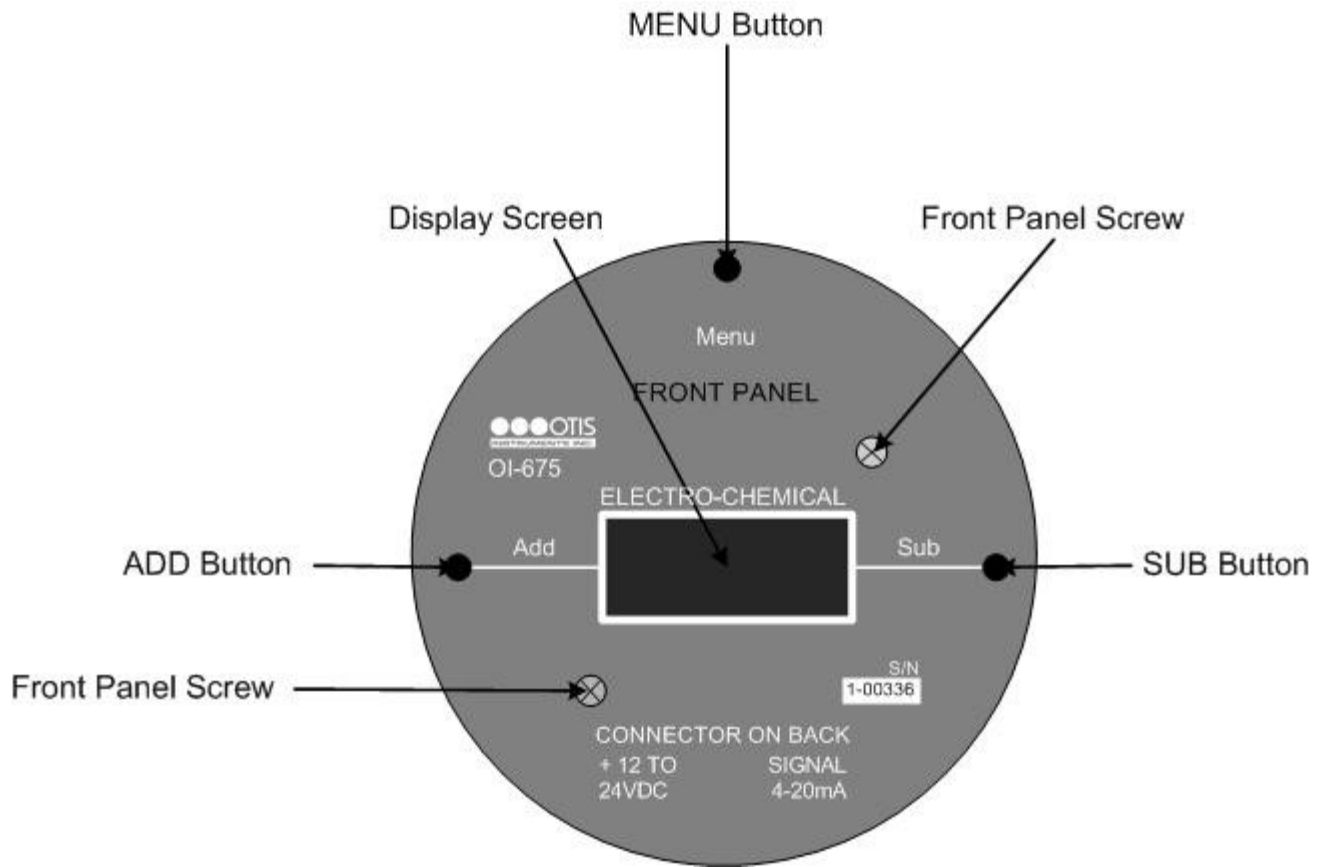

Wiring Configurations

To ensure full-functionality, complete ALL of the following Wiring Configurations before installing the device in the field.

Sensor Assembly to Monitor Connection

1. Unscrew, remove and set aside the explosion proof Moore lid.

NOTE: Do not touch any metal object to the OI-675 internal components.

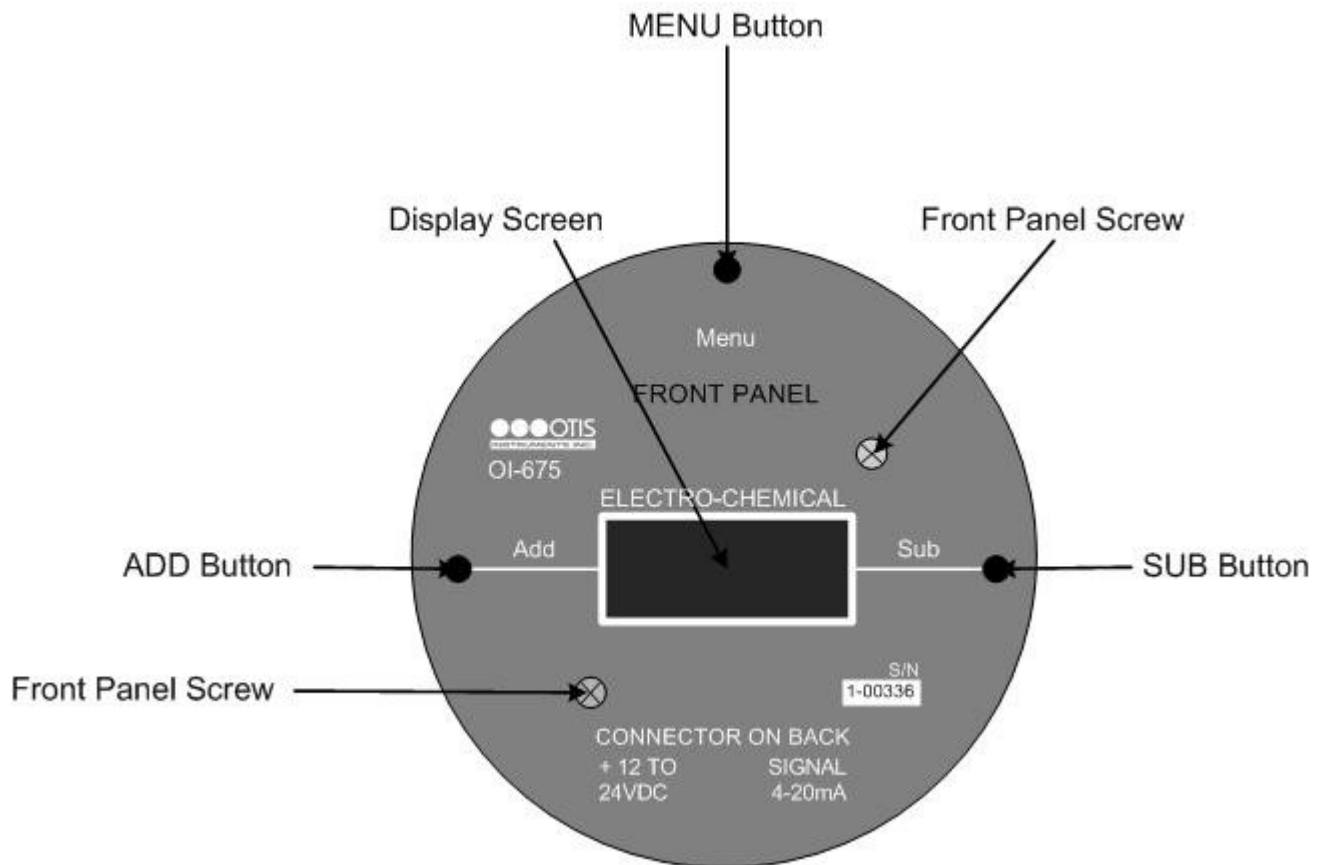

Sensor Configuration cont...

2. Verify that the monitor is properly connected to the terminal on the Back Panel by ensuring that the sensor wires are configured as follows:
 - Signal wire to 4-20mA (signal)
 - Positive Power Supply wire to V++ (positive)

NOTE: Make sure that the cable from the monitor is sealed where it enters the Moore Enclosure. This verification will aid in maintaining the device's reputable explosion proof classification and will help to prevent water exposure.

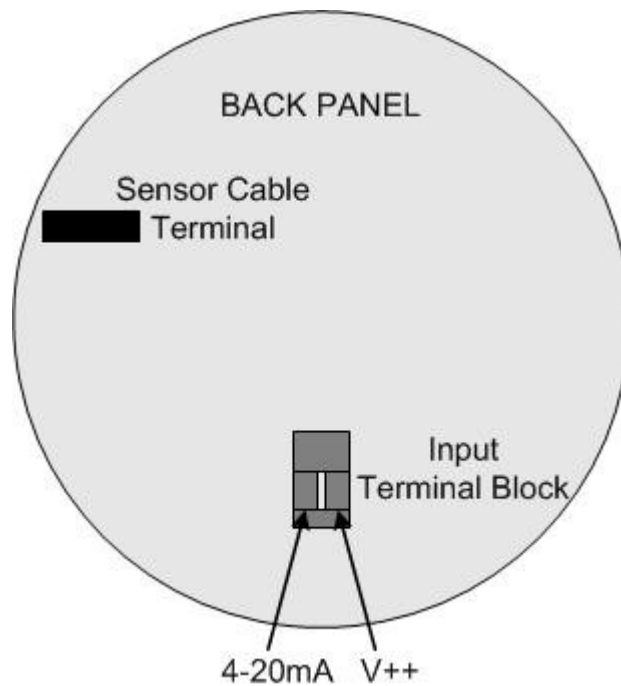

3. Verify that the wires have been secured in the terminal with a setscrew.
4. Once the Sensor Assembly to Monitor Configuration is complete, proceed to the next step.

Power Supply Configuration

1. After the Sensor Configuration has been completed (see above), supply 12-24 Volts DC power to the OI-675 (from the monitor or power supply).
2. Once 12-24 Volts DC is powered to the OI-675, use a Digital Volt Meter (DVM) to verify the voltage according to the following instructions:
 - Set the DVM to measure DC Volts.
 - Place the end of the DVM's red lead on the Input Terminal marked "V++" (located on the Back Panel).
 - Place the DVM's black lead on the Input Terminal marked "4-20mA" (located on the Back Panel).
 - Verify that the voltage is between 12 and 24 Volts DC according to the DVM reading.

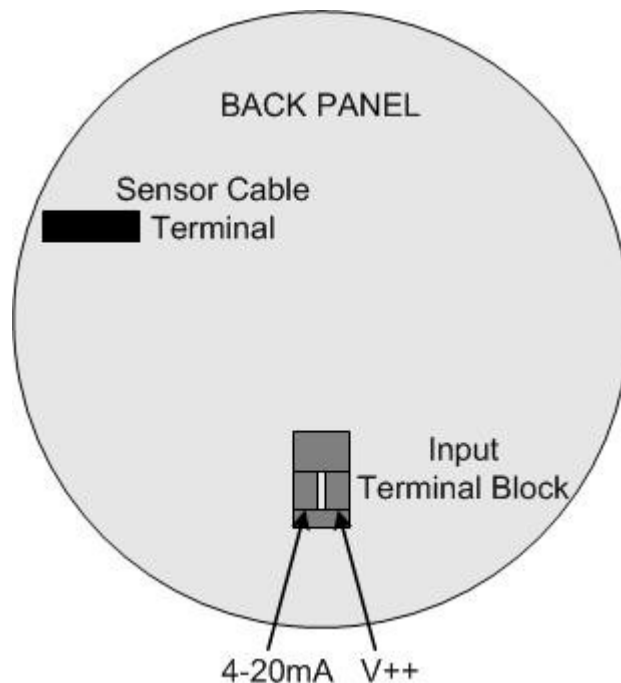

3. Once the voltage is verified, proceed to the Power On section of this Operation Manual.

NOTE: If the DVM reading is not between 12 and 24 Volts, check the connection and the DVM setting. If a problem persists, check the monitor's voltage output, sensor wire gauge, and wire length.

Power On

1. Apply power to the OI-675. The display screen on the Front Panel will show the software revision number (r 1.3).

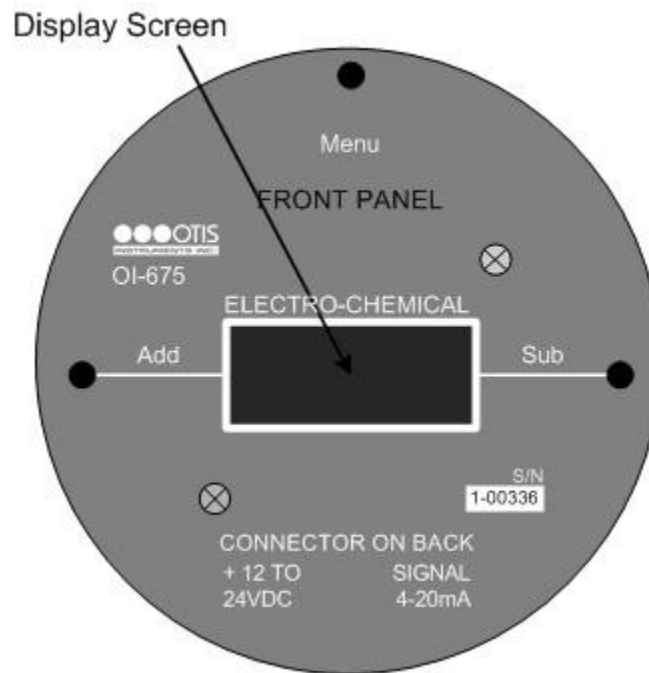

2. The device will then count up from 0 to 20.
3. When "0" is displayed, the device is in Normal Operating Mode.
4. Place the Moore enclosure lid on top of the Moore enclosure base.
5. Rotate the lid until it is tightly screwed in place (approximately 20 rotations).

NOTE: This device can only be turned "on" and "off" by its power supply.

Calibration

System calibration is necessary for the device to accurately sense toxic gases and send messages to the transmission monitor in relation to gas presence in parts per million. Before setting the calibration, the Null must first be set to zero (except when calibrating an O₂ sensor). Each time a sensor is replaced the device must be re-calibrated.

The OI-675 operates with a 12-24 Volt DC powered OI-352 Amplifier Card. The OI-352 is a 4 to 20mA signal output in which the 4mA signal equals “0” and the 20mA signal equals “full-scale”.

The Model OI-675 is also equipped with a dual set of switches for *MENU*, *ADD* and *SUB*. The manual and magnet switches are located on the Front Panel. Manual switching may be used in calibration when the explosion proof enclosure lid is removed. The magnet switches, for non-intrusive calibration, are activated by an Otis Instruments, Inc. distributed magnet.

NOTE: Although the OI-352 has a signal output that is measured in current (mA), the device's display screen—where the calibration is read from—is labeled as PPM. This label does not influence the reading and should be ignored while measuring mA.

NOTE: The DVM is not used during Calibration.

NOTE: There is not a user-settable Null feature available if calibrating an O₂ sensor assembly. If calibrating an O₂ sensor assembly, skip directly to the section titled “Setting Calibration”.

Change/Check Null

1. Touch an Otis Instruments, Inc. distributed magnet to the top side of the device to activate the *MENU* button.

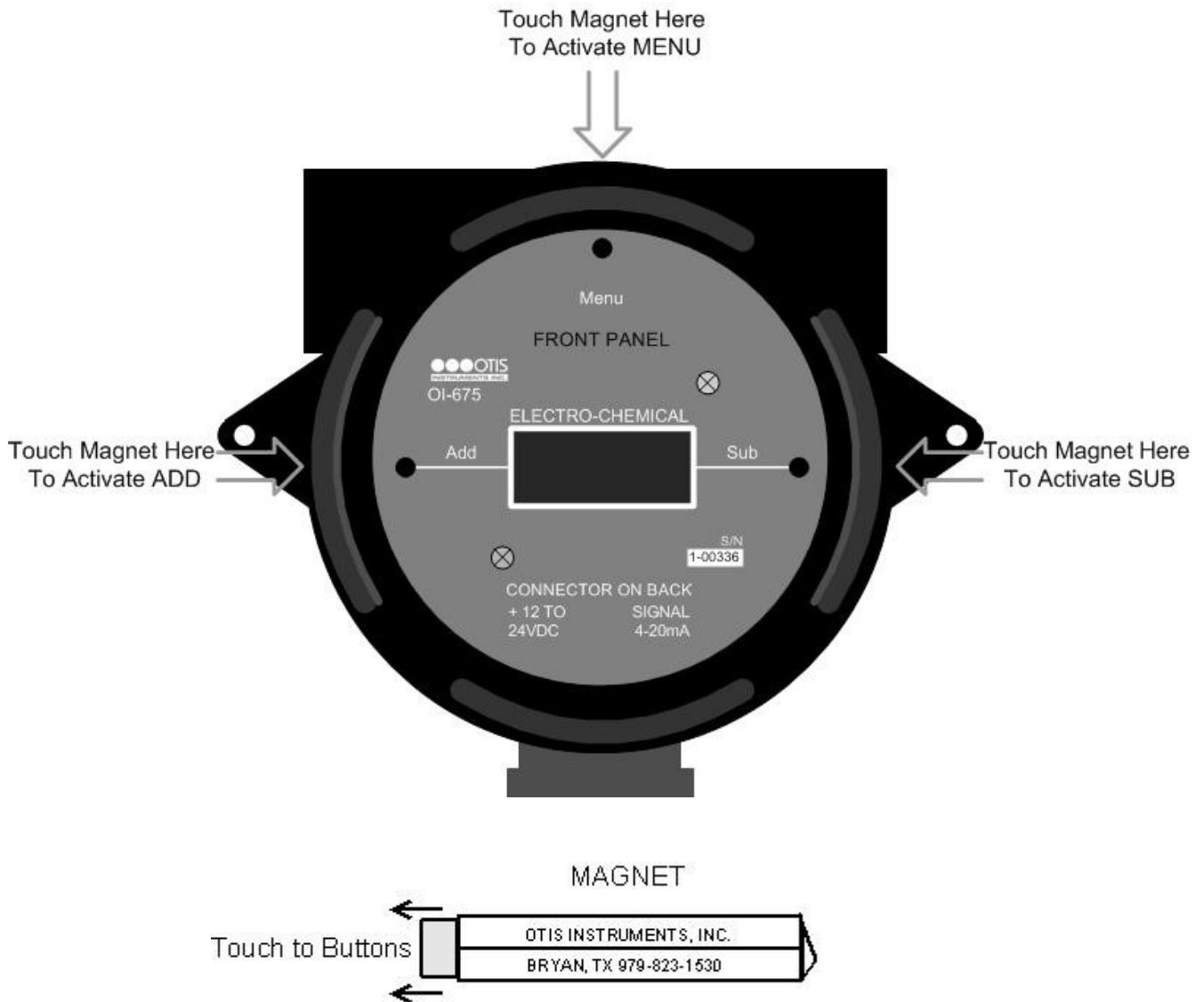

2. The display screen will show two dots and then "nuL".

NOTE: A message will be sent to the receiving monitor indicating that the sensor is in Calibration Mode, causing the alarm relays to inhibit.

Change/Check Null cont...

3. If the Null (zero) has already been set, a “0” will then be displayed.
4. If the Null is not set to zero, touch the magnet to the right side of the device to activate the *SUB* (*decrease*) button. Continue touching the magnet to the *SUB* button until the number shown on the display screen is “0”.
5. Once the Null is set, proceed to the next step.

Setting Calibration

1. After the Null has been set (see above), touch an Otis Instruments, Inc. distributed magnet to the top side of the device to activate the *MENU* button.

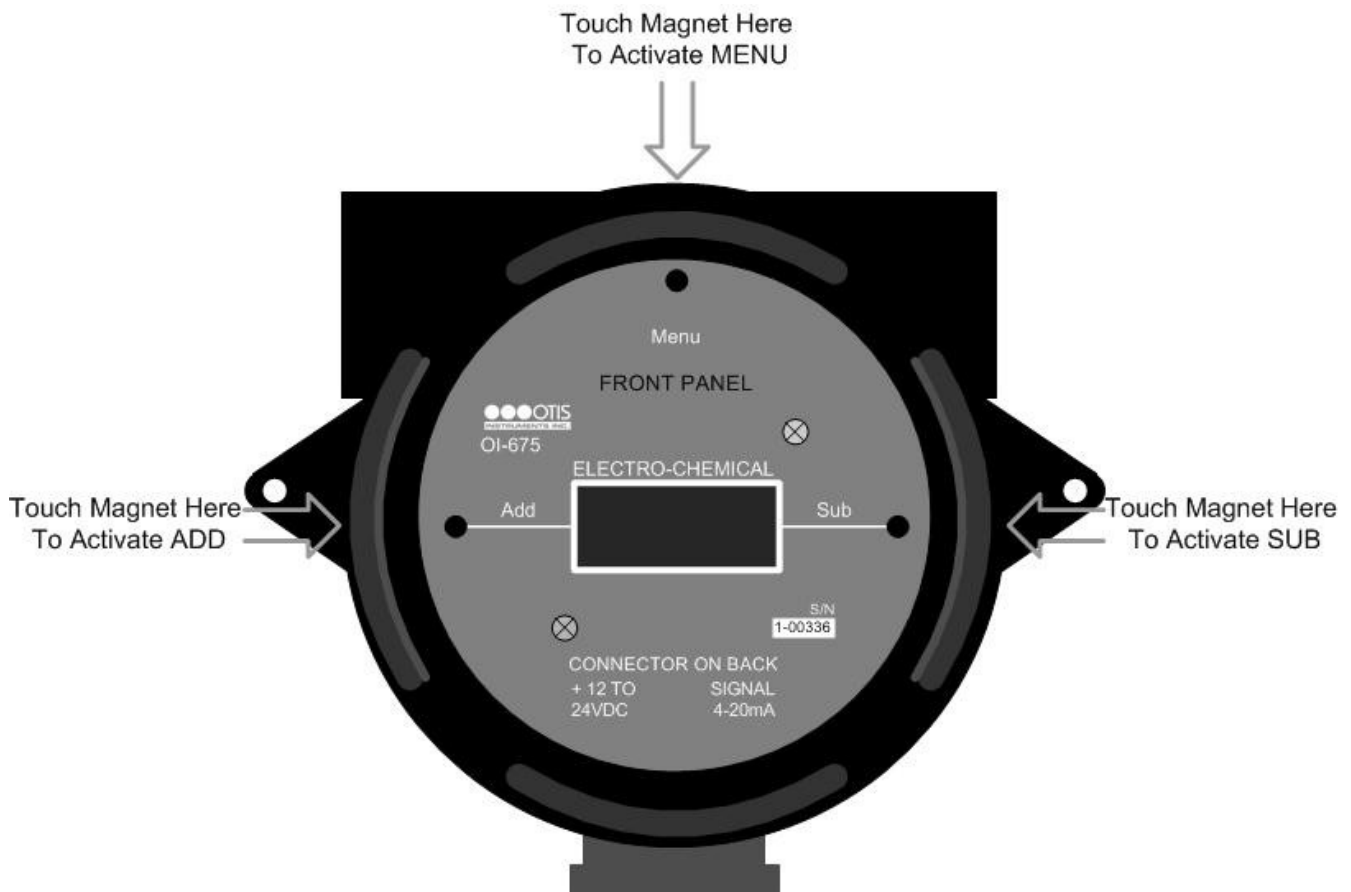

Setting Calibration cont...

2. The display screen will flash "CAL".
3. Unscrew and remove the sensor rainguard from the sensor housing cap.

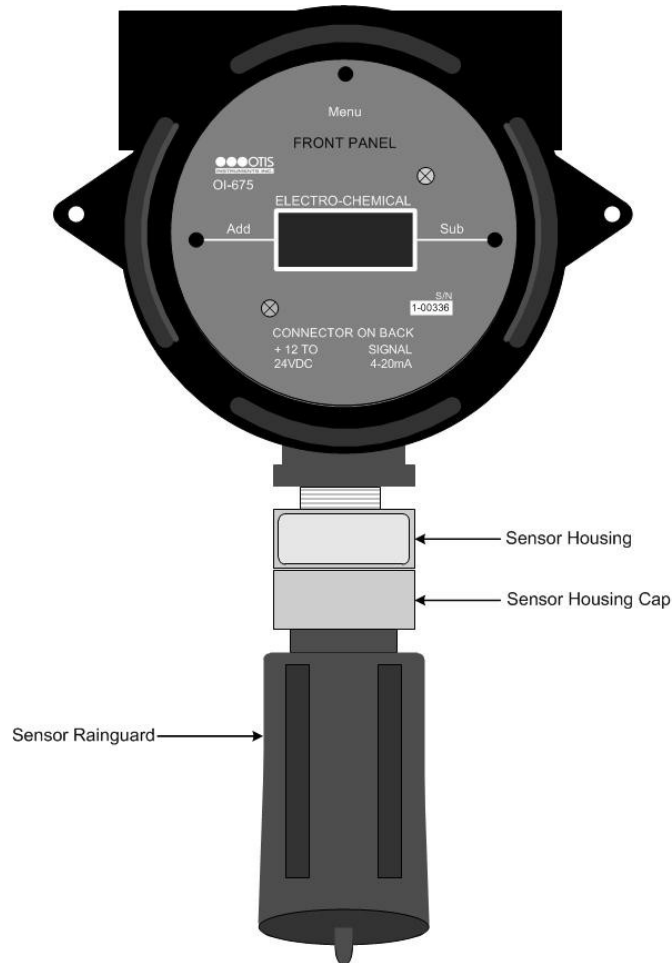

4. Replace the sensor rainguard with an Otis OI-410 Calibration Cup.
5. Apply a known calibration gas to the OI-410 Calibration Cup that is attached to the sensor housing.
6. The sensor's detection of gas will begin to climb in value as shown on the display screen.
7. Watch the display screen until the number displayed stops increasing.
8. Touch the magnet to *ADD* (increase) or *SUB* (decrease) to manipulate the reading on the display screen to match that of the calibration gas.

EXAMPLE: If the calibration gas is 25 PPM and the number on the display screen is 22 PPM, touch the magnet to *ADD* three times.

Setting Calibration cont...

9. The device is now calibrated.
10. Unscrew the OI-410 Calibration Cup.
11. Reattach (screw on) the sensor rainguard to the sensor housing cap.

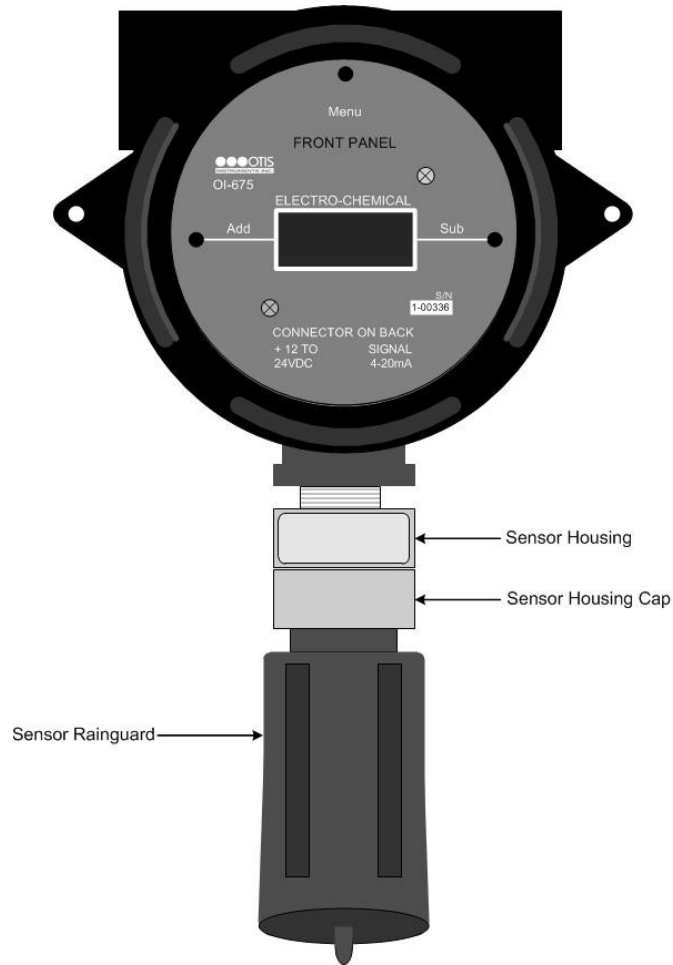

12. Touch the magnet to *MENU* to exit Calibration Mode.

NOTE: Calibration is now complete and the Relay/Alarms are active.

Sensor Replacement

The device contains an Electrochemical “4” Series sensor that detects gas in parts per million. Given that the sensor must be fully functional in order to alert technicians of the presence of toxic gas, sensor replacement may be necessary throughout the duration of the device's use to ensure optimal performance and reliability.

1. Unscrew, remove and set aside the explosion proof Moore lid.
2. Lift the Front Panel out of the enclosure.
3. Unplug the sensor data cable from the sensor cable terminal on the Back Panel.
4. Firmly grasp the sensor housing.
5. Unscrew the rainguard and sensor housing cap from the sensor housing.

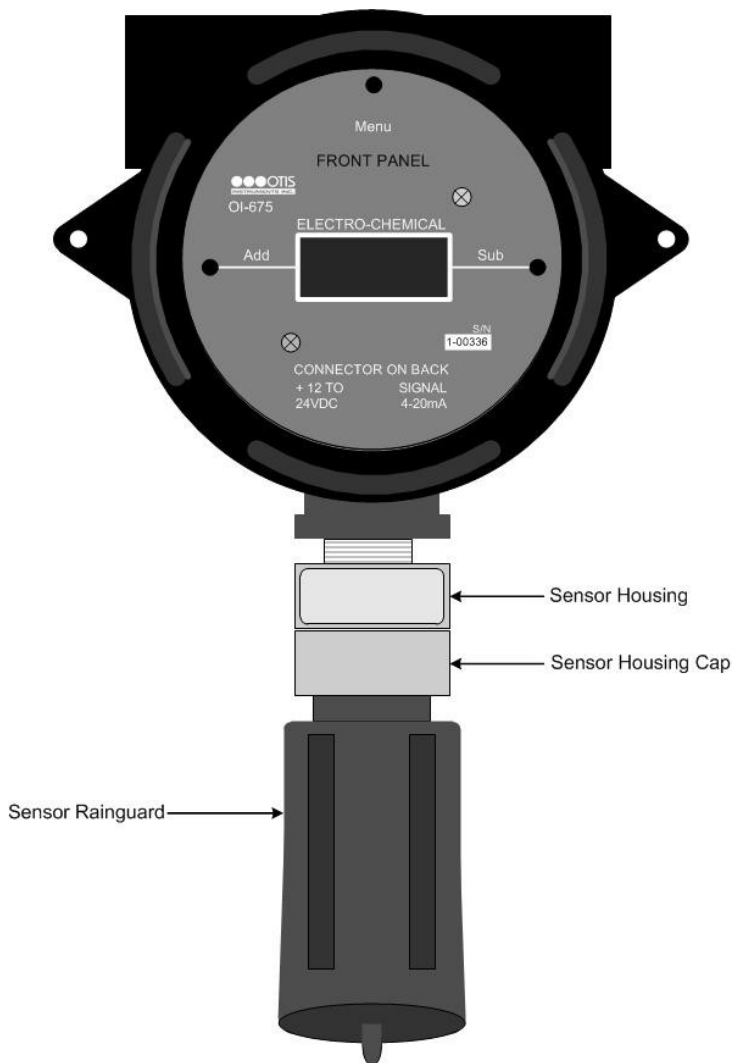
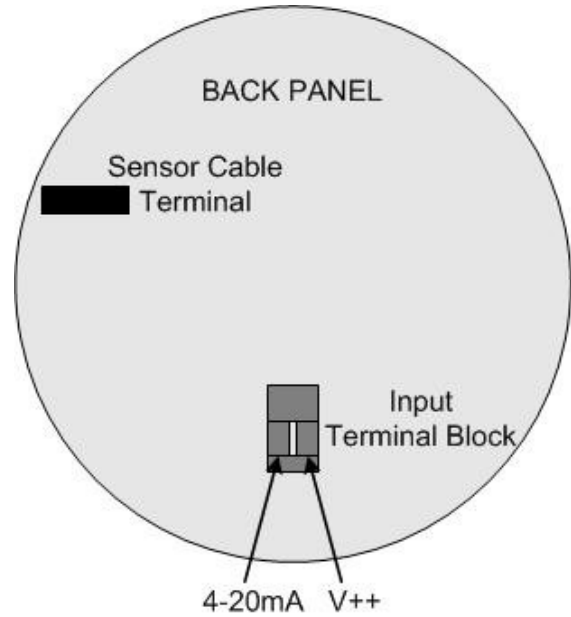

Sensor Replacement cont...

- Using the thumb and forefinger, pull firmly and evenly to slide the sensor out of the sensor housing.

NOTE: Do not use any metal object to remove the sensor.

- Slide the new sensor into device, matching the sensor prongs to the corresponding eyelets inside.

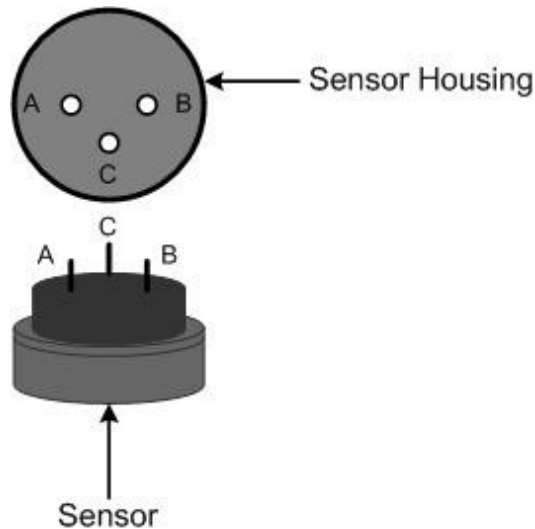

- Press the sensor into place.
- Screw the rainguard and sensor cap housing back onto the sensor housing.
- Plug the sensor data cable back into the sensor cable terminal on the Back Panel by:
 - Matching up the notch in the terminal with the lock on the cable end connector
 - Pushing the cable end connector into the terminal
- Place the Moore enclosure lid on top of the Moore enclosure base.
- Rotate the lid until it is tightly screwed in place (approximately 20 rotations).

NOTE: Once the sensor has been changed the Null must be set back to 0 and then the device must be re-calibrated.

Specifications

Power Input:	12-24 VDC
Power Output:	4-20 mA
Sensor:	Electrochemical “4” Series
Certification:	CSA Certified Class I, Div. 1 Groups C & D
Ambient Temperature Range:	-20 to 50° C -4 to 122° F
Accuracy:	+/- 5% full-scale
Warranty:	Hardware: One-year (Limited) Software: 90-days from ship date Sensor: 1-2 years (varies w/ sensor type)

Warranty Statement for **OI-675 Electrochemical Sensor Assembly**

Hardware

Otis Instruments, Inc. (Manufacturer) warrants its products to be free of defects in workmanship and materials—under normal use and service—from the date of purchase from the manufacturer or from the product's authorized reseller. The hardware for this device is under a one-year limited warranty.

The manufacturer is not liable (under this warranty) if its testing and examination disclose that the alleged defect in the product does not exist or was caused by the purchaser's (or any third party's) misuse, neglect, or improper installation, testing or calibrations. Any unauthorized attempt to repair or modify the product, or any other cause of damage beyond the range of the intended use, including damage by fire, lightening, water damage or other hazard, voids liability of the manufacturer.

In the event that a product should fail to perform up manufacturer specifications during the applicable warranty period, contact the product's authorized reseller or return the product directly to the manufacturer with a Return Material Authorization (RMA). This number will be assigned upon contacting customer service at 979.776.7700 or Otis@otisinstruments.com. The manufacturer will—at its option and expense—repair or replace the product, or deliver an equivalent product or part to the purchaser at no additional charge.

Any replaced or repaired product or part has either a 90-day warranty or the remainder of the initial warranty period (whichever is longer).

Software

Software and documentation material are developed to the purchaser's specification and is considered “custom” software. The software, therefore, is supplied “as is,” without warranty as to their performance, merchantability or fitness for any particular purpose.

However, the diskette media containing the software are covered by a 90-day warranty that protects the purchaser against failure within that period.

Sensor

The sensor contained in the device is covered under a 1-2 year limited warranty that varies with the sensor type.

Otis Instruments, Inc.

301 South Texas Avenue
Bryan, TX 77803

Corporate Office: 979.776.7700

service@otisinstruments.com

www.otisinstruments.com