

GEN²

Model OI-7530
The Relayer

Operation Manual

Revision 2.3w



Product Overview

The Gen II WireFree *Relayer* OI-7530 is a 32-channel 3-relay wireless relay/alarm system specifically designed for use in conjunction with Otis Instruments, Inc. Gen II WireFree Sensor Assemblies.

The OI-7530 can monitor up to 32 sensors. The ability to mount the device near the entrance of a site allows the technician to immediately determine if it is safe to enter the site, making this device incredibly useful in any environment hosting hazardous gas. The OI-7530 can be mounted as a traditional or self-contained system that requires 12-24 Volts DC or 120/240 Volts AC. The OI-7530 receives transmissions from WireFree sensors via an on-board 900MHz (expected release 1H 2011) or 2.4GHz Gen II radio.

These key features—and more—make the OI-7530 a reliable and convenient tool that is incredibly useful in any environment hosting hazardous gas.

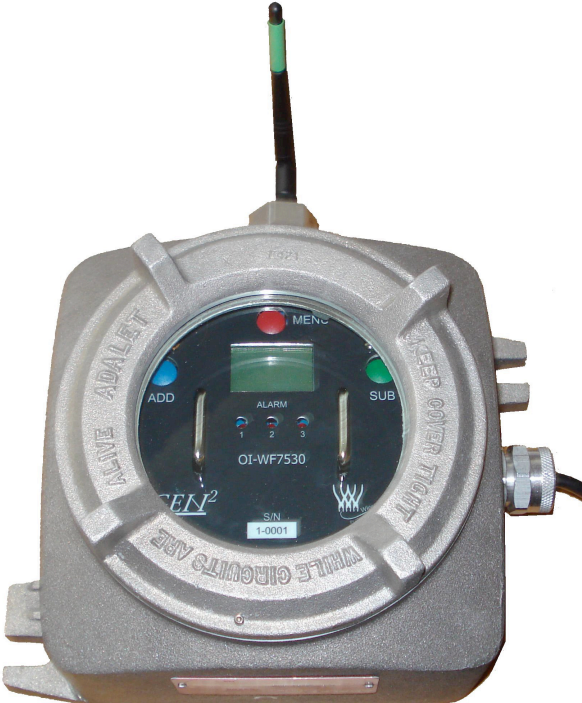

Table of Contents

- Product Overview**.....1
- Introduction**.....1
- Warnings**.....1
- Recommendations**.....1
- Complete System Diagrams**.....1
 - Complete System*.....1
 - Control Board*.....1
 - Internal Diagram (Basic DC Wiring – From Factory)*.....1
 - Internal Diagram (Basic AC Wiring – From Factory)*.....1
- Power On**.....1
- Power Off**.....1
- Basic Configuration Menu: Individual Channel Setup**.....1
 - Channel Selection*.....1
 - Channel On/Off*.....1
 - Radio Address Setting*.....1
 - Relay On/Off*.....1
 - Relay Setting-Type (Rise/Fall)*.....1
 - Relay Value Setting*.....1
 - Relay Latching/Unlatching*.....1
 - Duplicate Channel*.....1
- Advanced Configuration Menu (Global Settings)**.....1
 - Entering Advanced Configuration Menu*.....1
 - Adjusting LCD Contrast*.....1
 - Restore Factory Default Settings*.....1
 - Fault Relay Setup: Relay 3 Fault Relay*.....1
 - Fault Relay Setup: Latching or Unlatching*.....1
 - Radio Timeout Setting*.....1
 - Network Channel Setting*.....1
 - Primary/Secondary Setting*.....1
- Relay/Alarm Tests**.....1
 - Relay 1 (Low Alarm) Test*.....1
 - Relay 2 (High Alarm) Test*.....1
 - Relay 3 (Danger Alarm) Test*.....1
- Antenna Replacement**.....1
- APPENDIX A: AC Wiring Configurations**.....1
 - AC Power Supply Wiring Configurations*.....1
 - Relay 1 (Low Alarm) Wiring Configurations*.....2
 - Relay 2 (High Alarm) Wiring Configurations*.....2
 - Relay 3 (Danger Alarm) Wiring Configurations*.....2
 - Shown Above: AC Wiring Configurations – Complete Wiring Diagram (power and all three relays connected)*.....2
- APPENDIX B: DC Wiring Configurations**.....2
 - DC Power Supply Wiring Configurations*.....2
 - Relay 1 (Low Alarm) Wiring Configurations*.....2
 - Relay 2 (High Alarm) Wiring Configurations*.....2
 - Relay 3 (Danger) Wiring Configurations*.....2
 - DC Wiring Configurations - Complete Wiring Diagram (power and all three relays connected)*.....2
- APPENDIX C: OI-7530 Troubleshooting Guide**.....2
- APPENDIX D: Operation of Relays**.....3
 - “Dry” Contact and “Wet” Contact Relays*.....3
 - Normally Open and Normally Closed Relays*.....3
 - Failsafe Relays*.....3
- Specifications**.....3

Introduction

This document is an Operation Manual containing diagrams and step-by-step instruction for proper operation of the Otis Instruments, Inc. Gen II WireFree *Relayer* OI-7530. This document should be read before initial operation of the product.

Should a question arise during the use of the product, this document will serve as a first reference for consultation. If further questions arise, or if the device is not working properly, please contact the sales representative of this product.

Warnings



CAUTION: THE INTERNAL COMPONENTS CAN BE STATIC SENSITIVE. USE CAUTION WHEN OPENING THE ENCLOSURE AND HANDLING INTERNAL COMPONENTS.

- To ensure technician safety, always wire the relays before supplying power to the device.
- Do not open the enclosure while the area is classified as Class I Division 1.
- Do not open the enclosure if an explosive gas atmosphere may be present.
- The Otis Instruments Gen II WireFree *Relayer* OI-7530 enclosure is Class I Division 1 Certified. However, if the enclosure lid is removed, for whatever reason, the OI-7530 certification is not valid.

Recommendations

For optimal performance, the manufacturer recommends using a minimum of 22 gauge wire for all Wiring Configurations.

Different loads require different gauge wire. Use the appropriate wire size—depending on the voltage and current requirements.

Complete System Diagrams

The following diagrams should be consulted for identification of the system and all parts that may be referred to in this Operation Manual.

Complete System

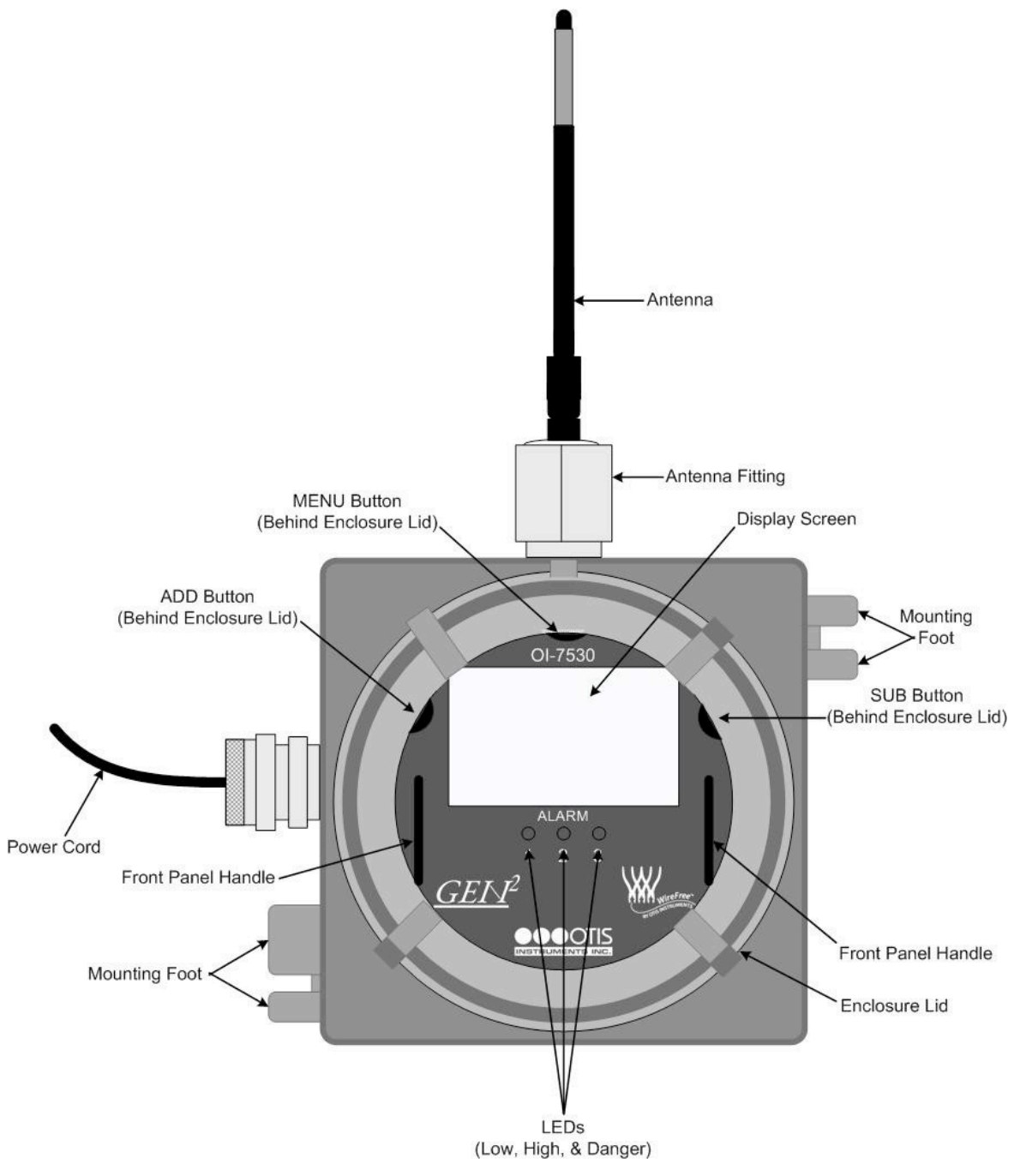

Control Board

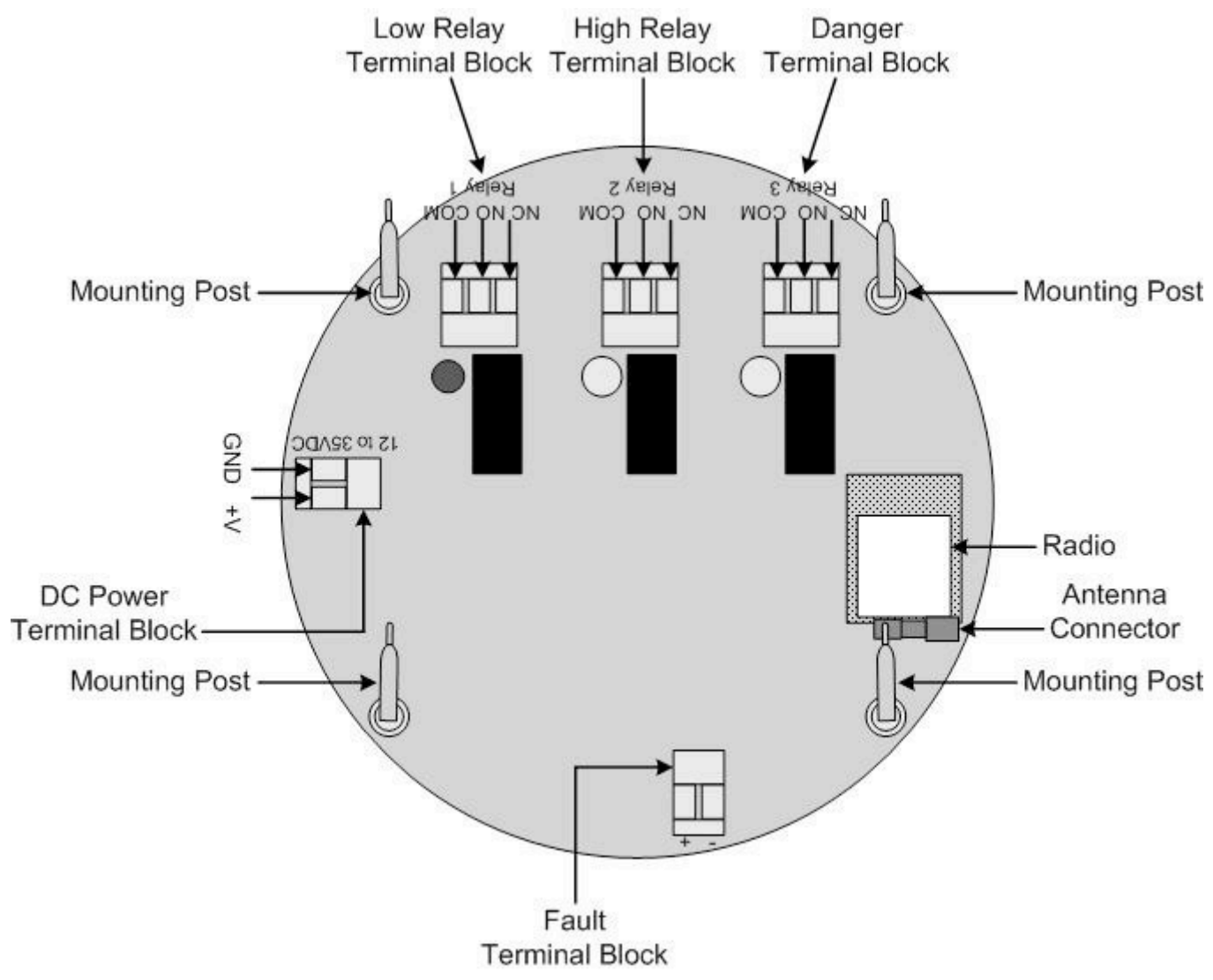

Internal Diagram (Basic DC Wiring – From Factory)

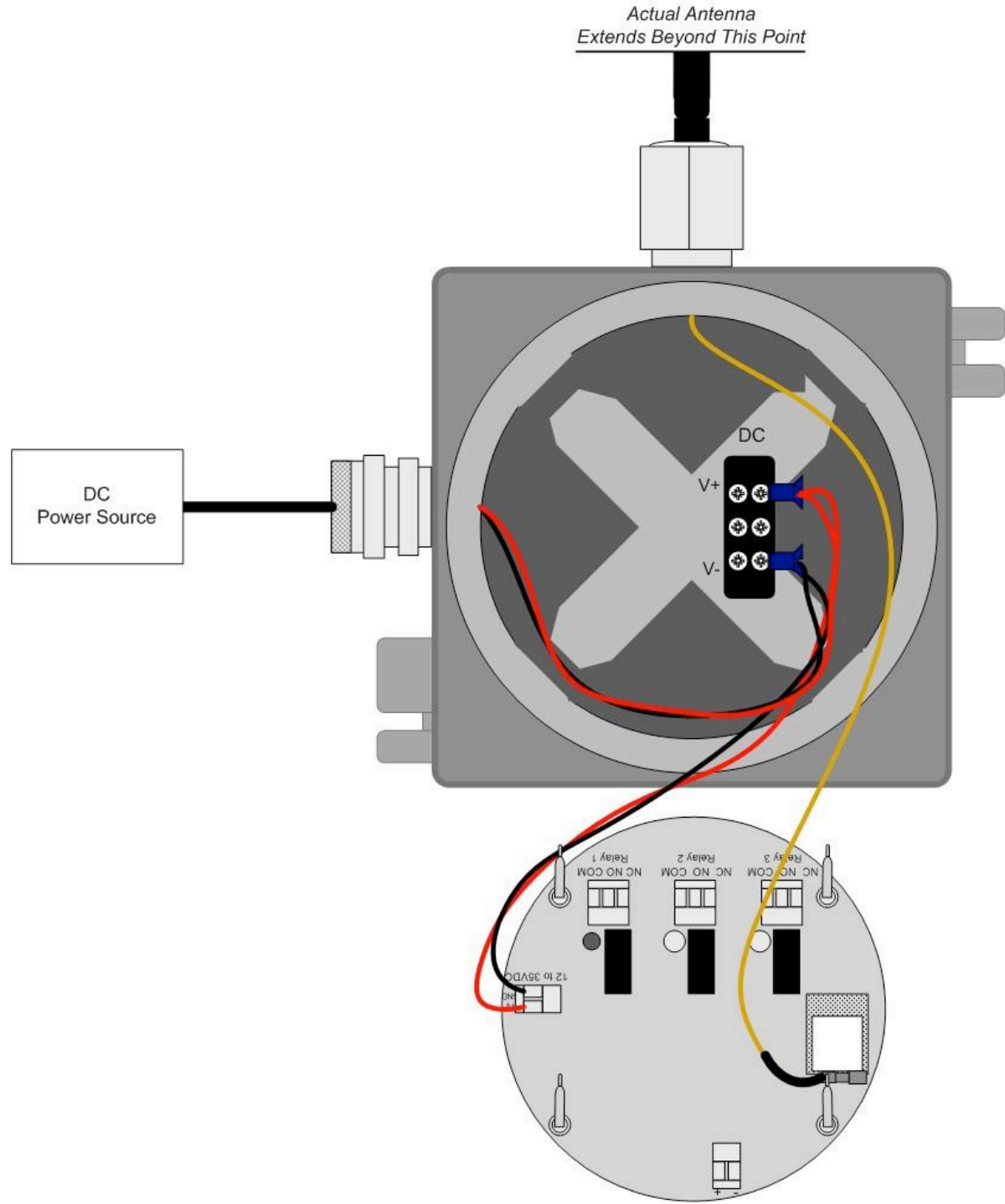

Internal Diagram (Basic AC Wiring – From Factory)

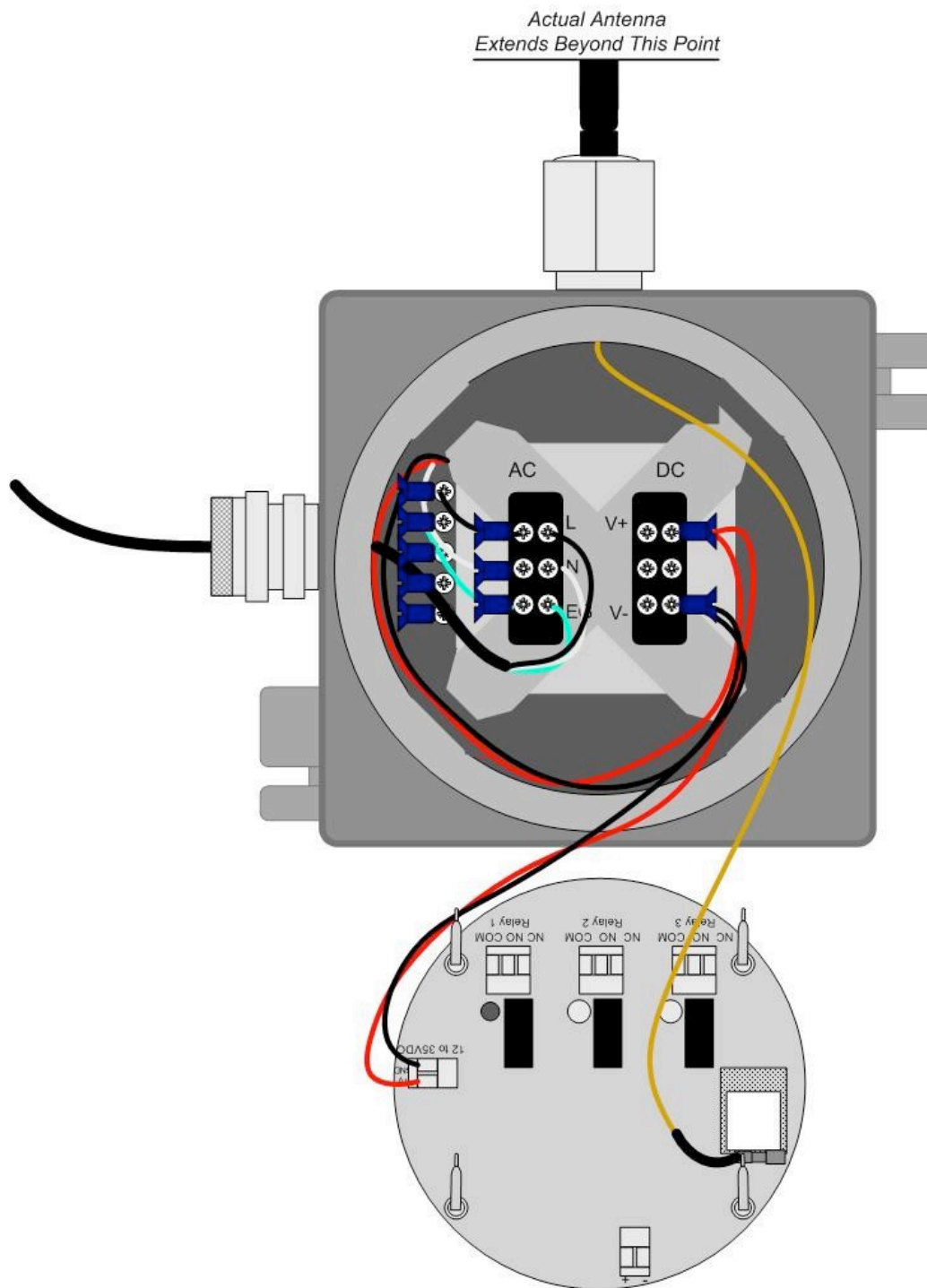

Power On

Powering on the device activates its functions. When powered on, the device is fully functional and access to system and settings menus is allowed.

NOTE: Do not open the enclosure while the area is classified as Class I Division 1, or if an explosive gas atmosphere may be present.

1. The OI-7530 will automatically Power On when the Power Wiring Configurations are complete and voltage is supplied to the unit.
2. The device will then count down from 10 to 0.

- From 10 to 5, the Display Screen will show the Otis Instruments, Inc. logo.
- From 5 to 0, the Display Screen should resemble the following illustration:

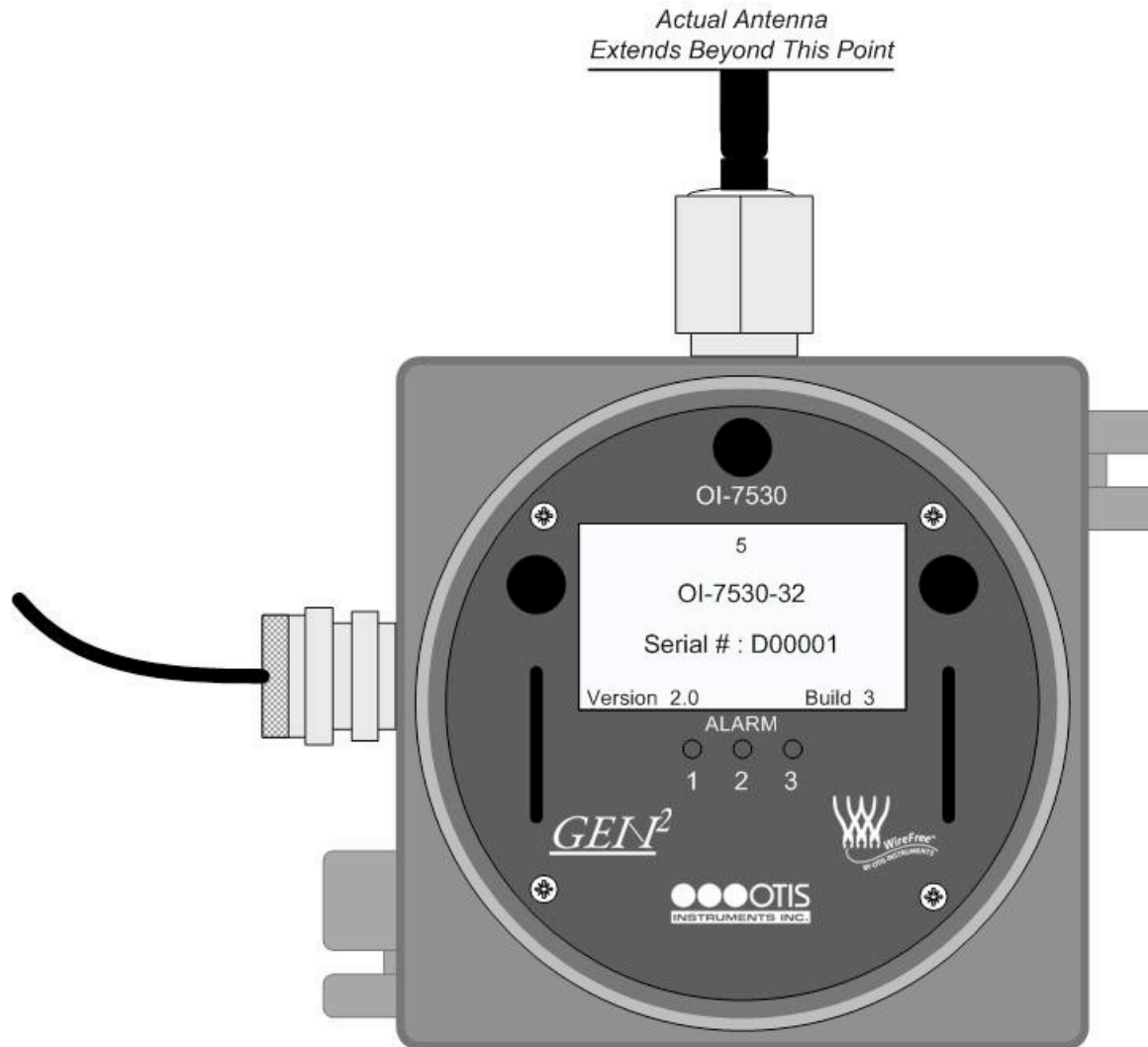

3. When the channel number is displayed, the device is in Normal Operating Mode and ready to operate. When in Normal Operating Mode, the display screen should resemble the following illustration:

NOTE: If a channel is in Fault, the display screen will show F(#).

NOTE: If the relays for a channel are active, the display screen will show "1", "2", or "3" for the corresponding active relay; the corresponding active LED will also be illuminated.

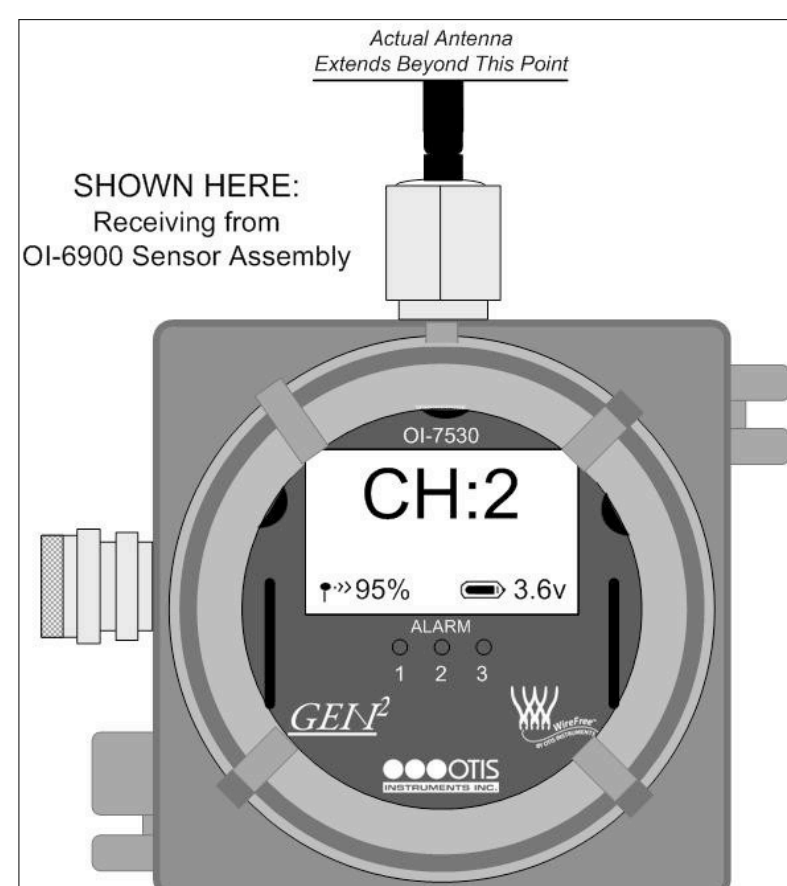
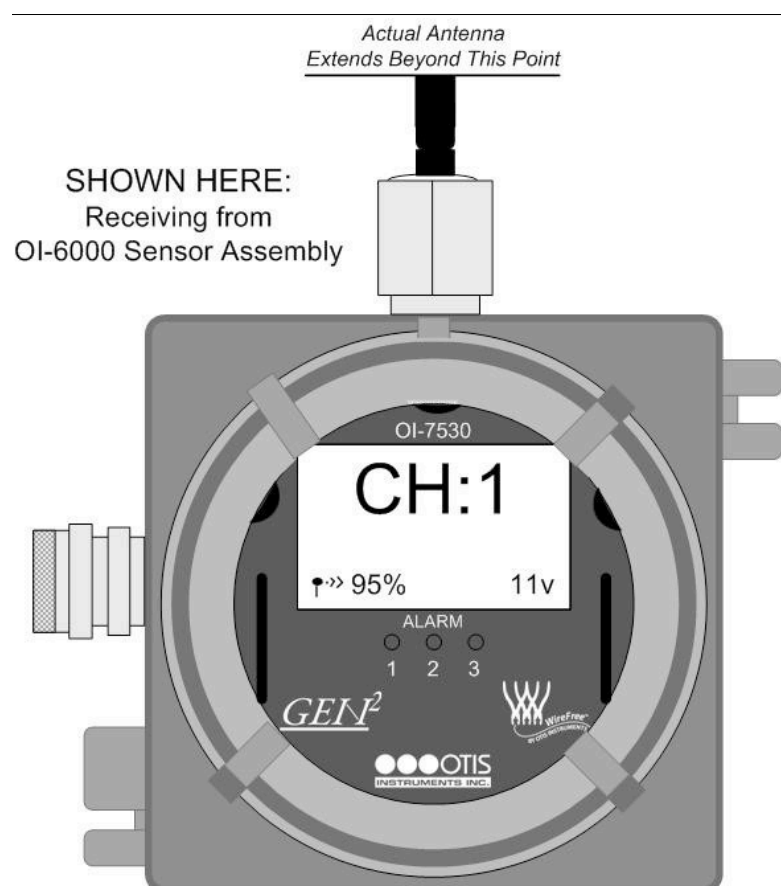

Power Off

Powering off the device shuts down the system. When powered off, the device will no longer receive radio signals from the sensors.

NOTE: Do not open the enclosure while the area is classified as Class I Division 1, or if an explosive gas atmosphere may be present.

The OI-7530 power is controlled by either an AC or DC power source; the OI-7530 will automatically Power Off when voltage is no longer supplied to the unit —by either turning off the voltage supply at the power source (DC power), or by unplugging the unit (AC power).

Basic Configuration Menu: Individual Channel Setup

This feature should be used to setup all channels (and their corresponding relays). The Basic Configuration Menu includes: Channel Selection, Channel On/Off, Radio Address Setting, Relay On/Off, Relay Setting Type (Rise/Fall), Relay Value, and Relay Latching/Unlatching for each of the channels (and each of the 3 relays per channel) that the device will be monitoring (up to 32).

Each channel must be setup individually for each sensor. Therefore, Individual Channel Setup must be completed the same number of times that there are sensors being monitored.

NOTE: Do not open the enclosure while the area is classified as Class I Division 1, or if an explosive gas atmosphere may be present.

Channel Selection

1. Unscrew, remove and set aside the explosion proof lid.
2. Press and hold *MENU* for five seconds.

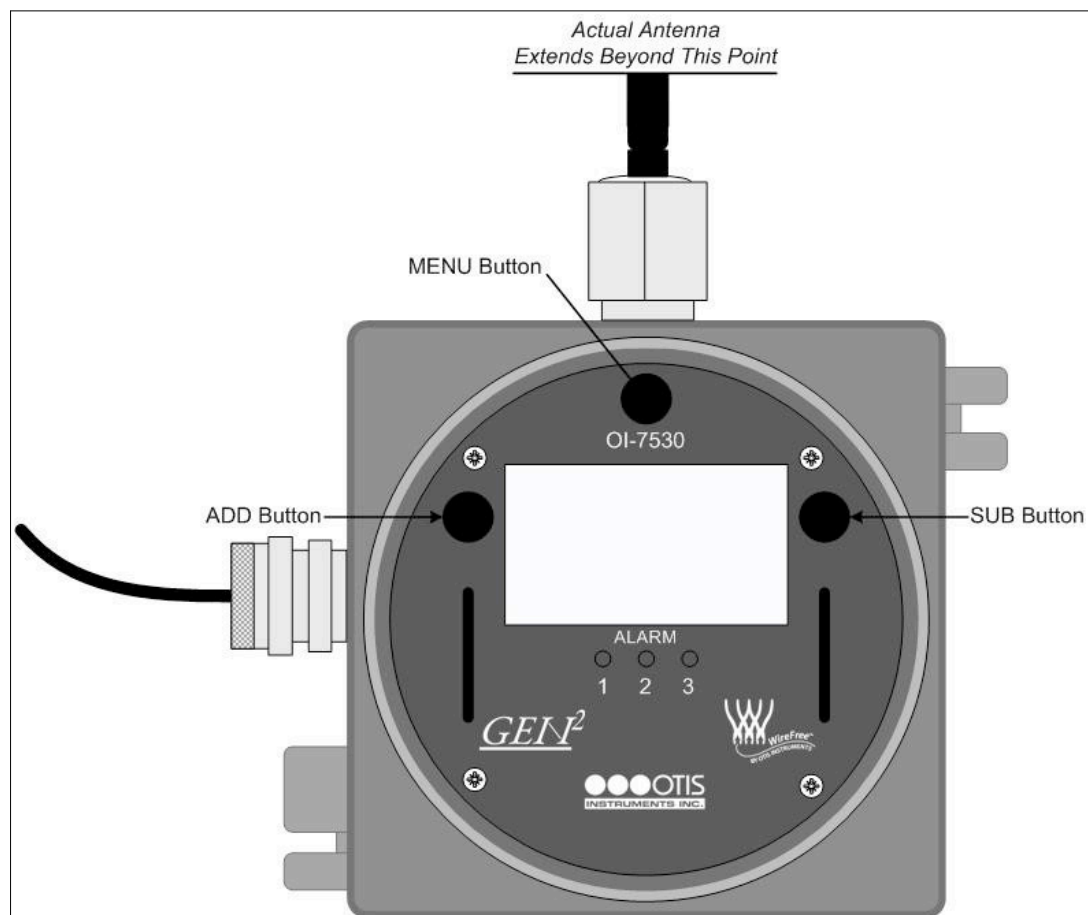

3. The display screen should resemble the following illustration (right):
4. Press *ADD* (increase) or *SUB* (decrease) to manipulate the Channel Selection setting (1-32).
5. Once the channel has been selected, proceed to the next step.

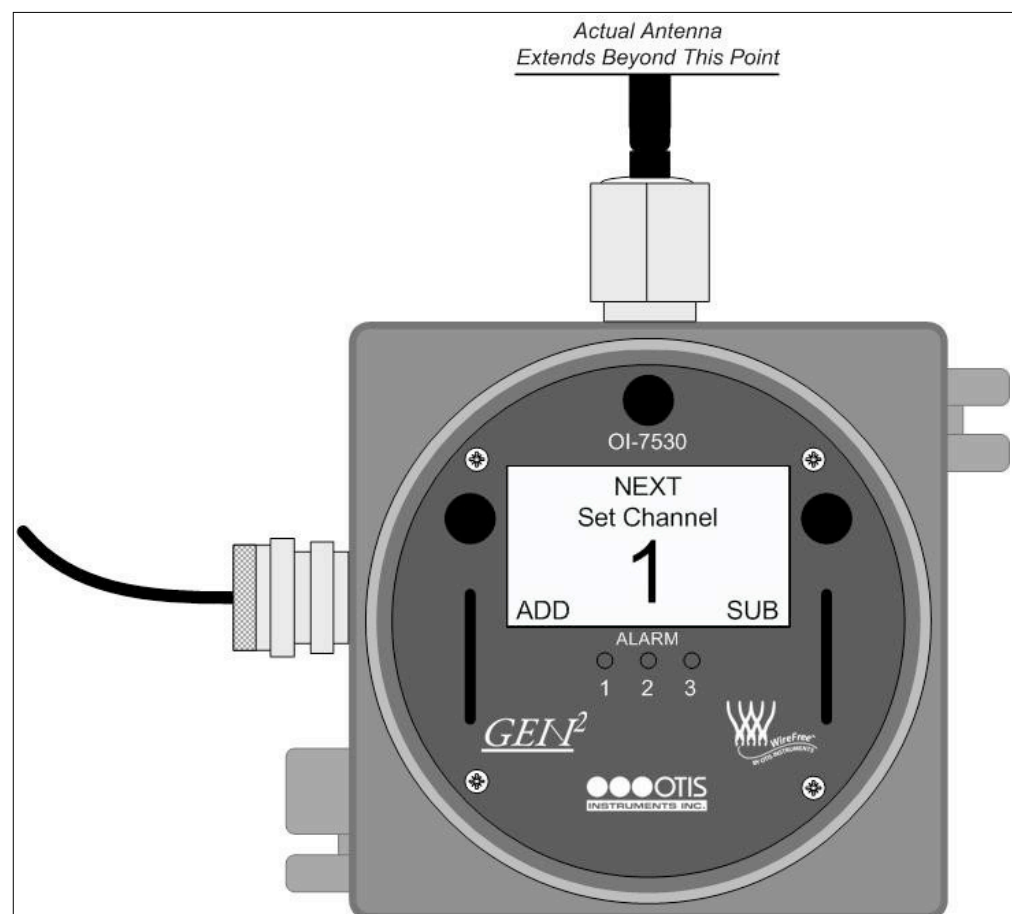

Channel On/Off

NOTE: When a channel is turned off, the unit will reset the channel readings and alarm settings.

1. After the channel has been selected (see previous section), press *MENU* once.
2. The display screen should resemble the following illustration:

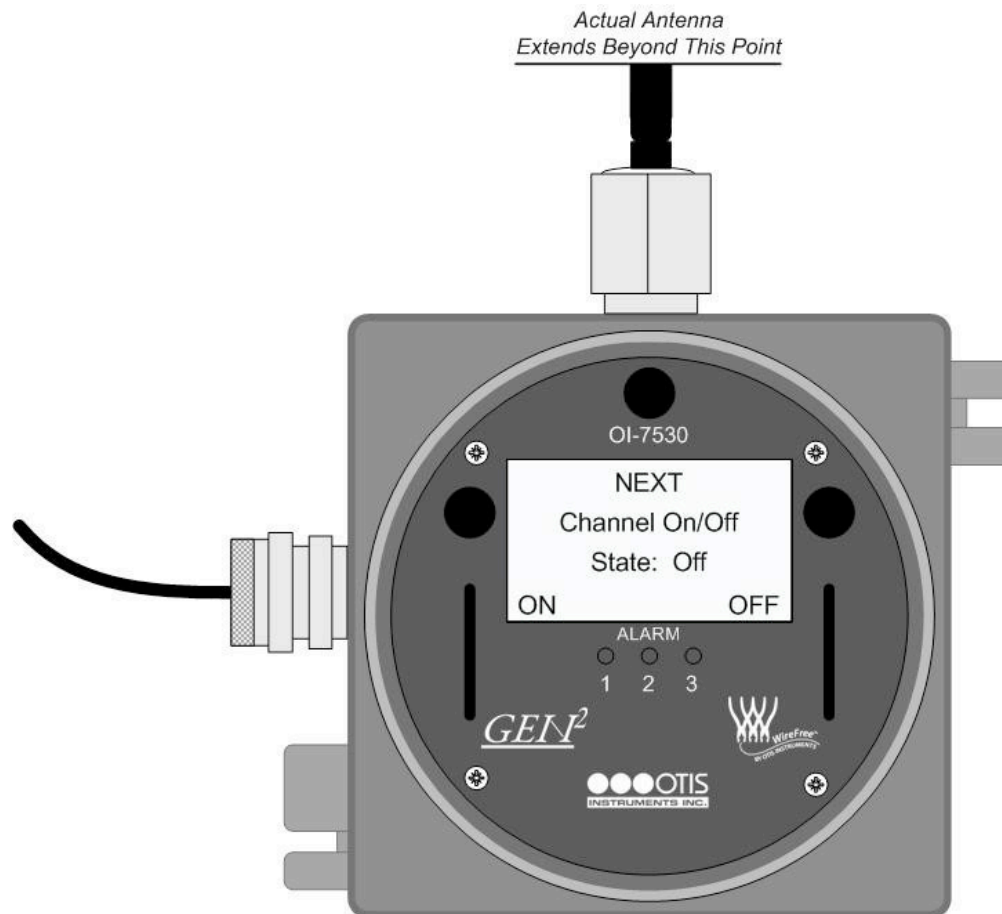

3. Press *ON (ADD)* or *OFF (SUB)* to manipulate the Channel On/Off setting.
4. If the channel is set to "On", proceed to the next step. If the channel is set to "Off", proceed to the "Duplicate Channel" section on page 24 of this Operation Manual.

Radio Address Setting

1. If the channel is set to "On" (see previous section), press *MENU* once.
2. The display screen should resemble the following illustration:

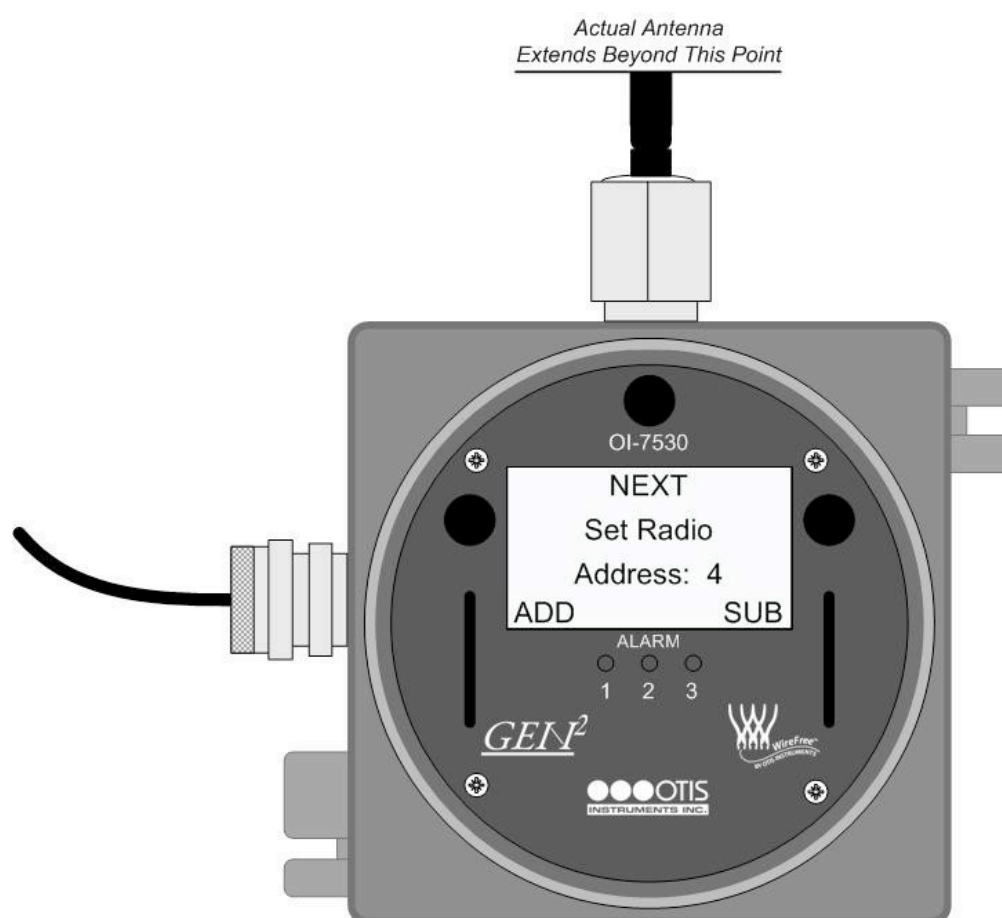

3. Press *ADD (increase)* or *SUB (decrease)* to manipulate the Radio Address.
4. Once the Address is set, proceed to the next step.

Relay On/Off

1. After the address has been set (see previous section), press *MENU* once.
2. The display screen should resemble the following illustration:

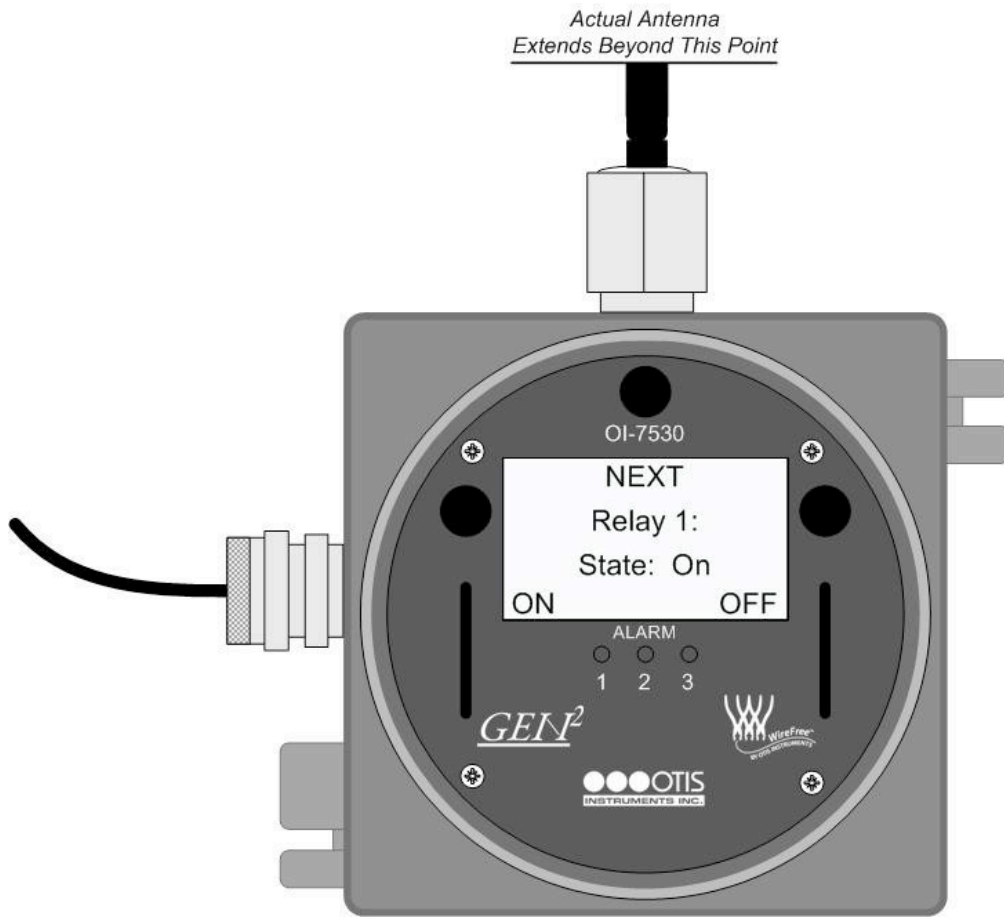

3. Press ON (*ADD*) or OFF (*SUB*) to manipulate the Relay On/Off setting.
4. If the relay is set to "On", proceed to the next step. If the relay is set to "Off", proceed to the "Duplicate Channel" section on page 24 of this Operation Manual.

Relay Setting-Type (Rise/Fall)

1. If the relay is set to "On" (as described in the previous section), press *MENU* once.
2. The display screen should resemble the following illustration:

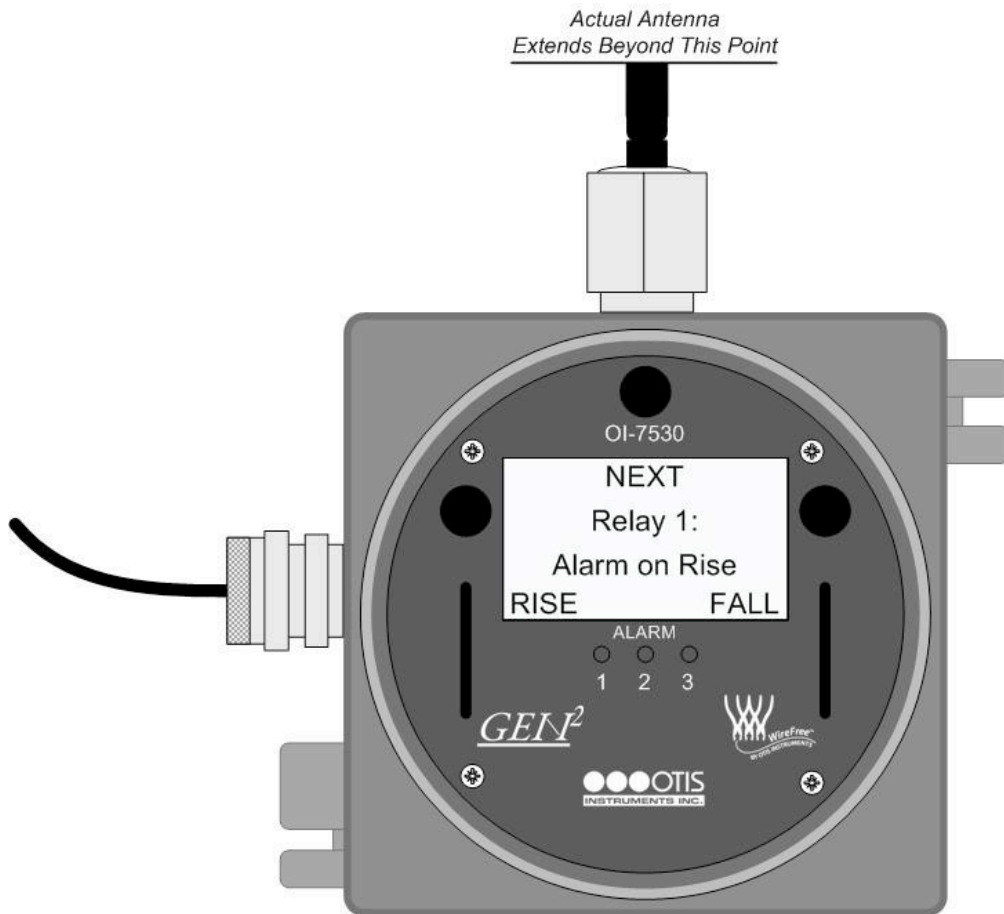

3. Press RISE (*ADD*) or FALL (*SUB*) to manipulate the setting type of the relay.
4. Once the Relay Setting-Type is set, proceed to the next step.

Relay Value Setting

1. Once the Relay Setting-Type has been selected (see previous section), press *MENU* once.
2. The display screen should resemble the following illustration:

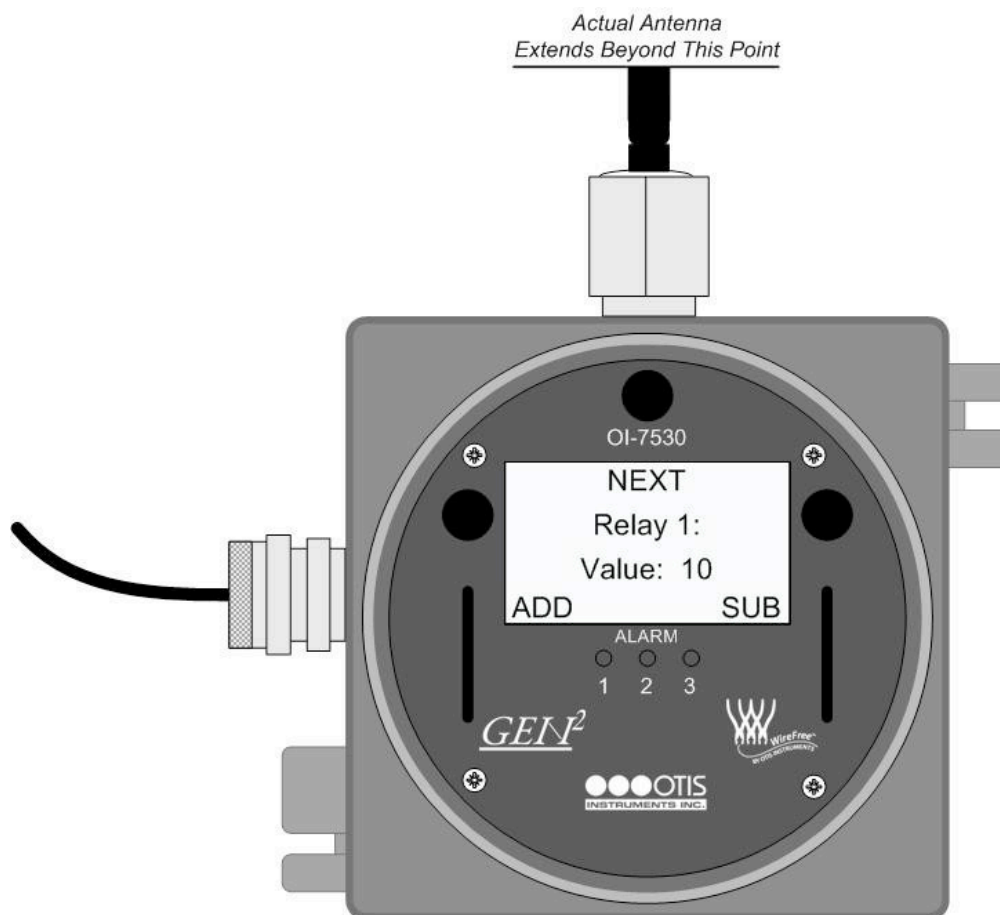

3. Press *ADD* (increase) or *SUB* (decrease) to manipulate the Relay Value Setting.
4. Once the Relay Value Setting is selected, proceed to the next step.

Relay Latching/Unlatching

1. Once the Relay Value has been selected (see previous section), press *MENU* once.
2. The display screen should resemble the following illustration:

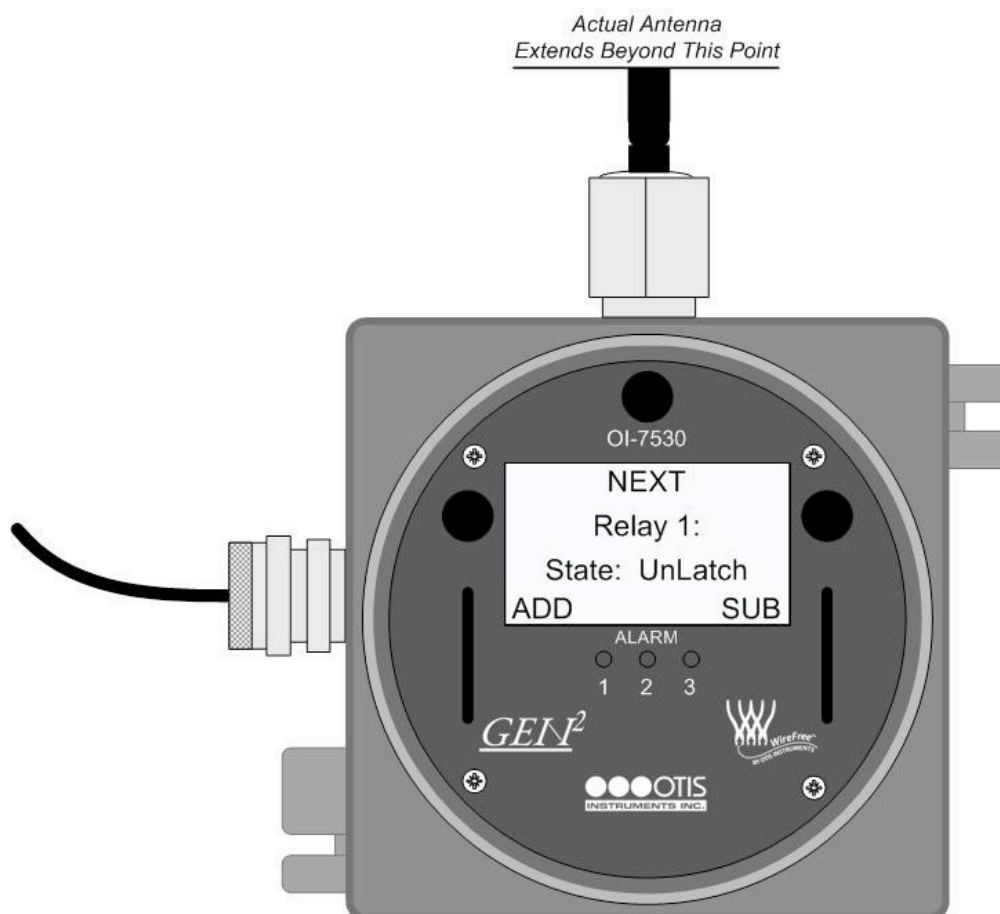

3. Press *ADD* (increase) or *SUB* (decrease) to manipulate the Relay Latching/Unlatching Setting.
4. Once Relay is set to latching or unlatching, proceed to the next step.

**RELAY SETUP MUST BE COMPLETED INDIVIDUALLY FOR EACH RELAY.
REPEAT THE RELAY SETUP STEPS (THE PREVIOUS FOUR SECTIONS) FOR EACH OF THE THREE
RELAYS.**

ONCE ALL THREE RELAYS HAVE BEEN SETUP, CONTINUE TO THE NEXT STEP.

Duplicate Channel

1. After the Channel has been setup (or turned off), press *MENU* once.
2. The display screen should resemble the following illustration:

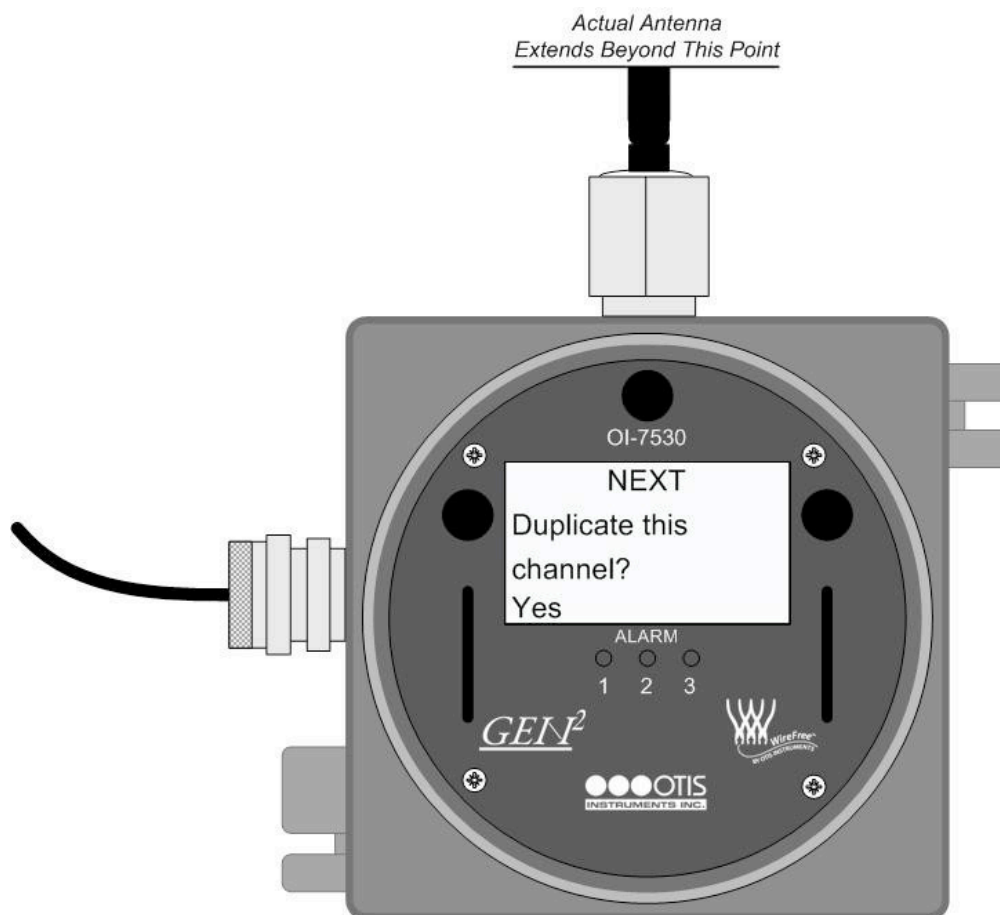

3. Press YES (*ADD*) to duplicate the channel. Press *MENU* to decline the duplication option and proceed to setup the next channel.

NOTE: To exit the Basic Configuration Menu, press ADD or SUB until the System Information appears, then press MENU.

**CHANNEL SETUP MUST BE COMPLETED INDIVIDUALLY FOR EACH CHANNEL.
REPEAT THE CHANNEL SETUP INSTRUCTIONS FOR EACH CHANNEL BEFORE USE.**

Advanced Configuration Menu (Global Settings)

The Advanced Configuration Menu is used to manipulate global settings. To setup individual channels, use the Basic Configuration Menu.

Entering Advanced Configuration Menu

1. Cycle the unit's power (turn OFF, then ON). Power off the device by turning off the voltage supply at the power source (DC power), or by unplugging the unit (AC power). Power on the device by supplying voltage to the unit.
2. When the Otis Logo is shown on the Display Screen, touch an Otis Instruments, Inc. distributed magnet to *MENU*.

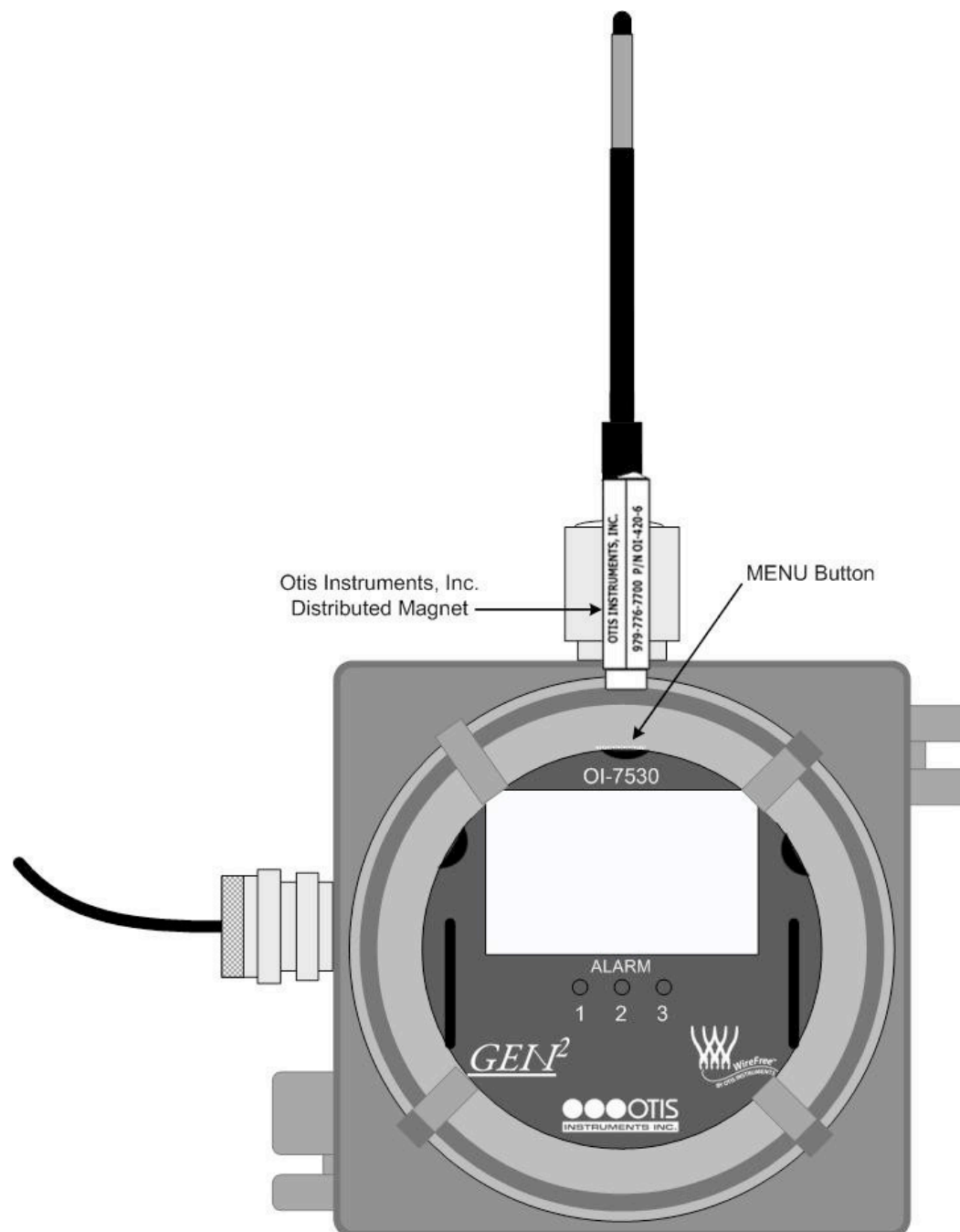

Adjusting LCD Contrast

Touch *ADD* (increase) or *SUB* (decrease) to manipulate the LCD contrast. Touch *MENU* (Next) to confirm the setting.

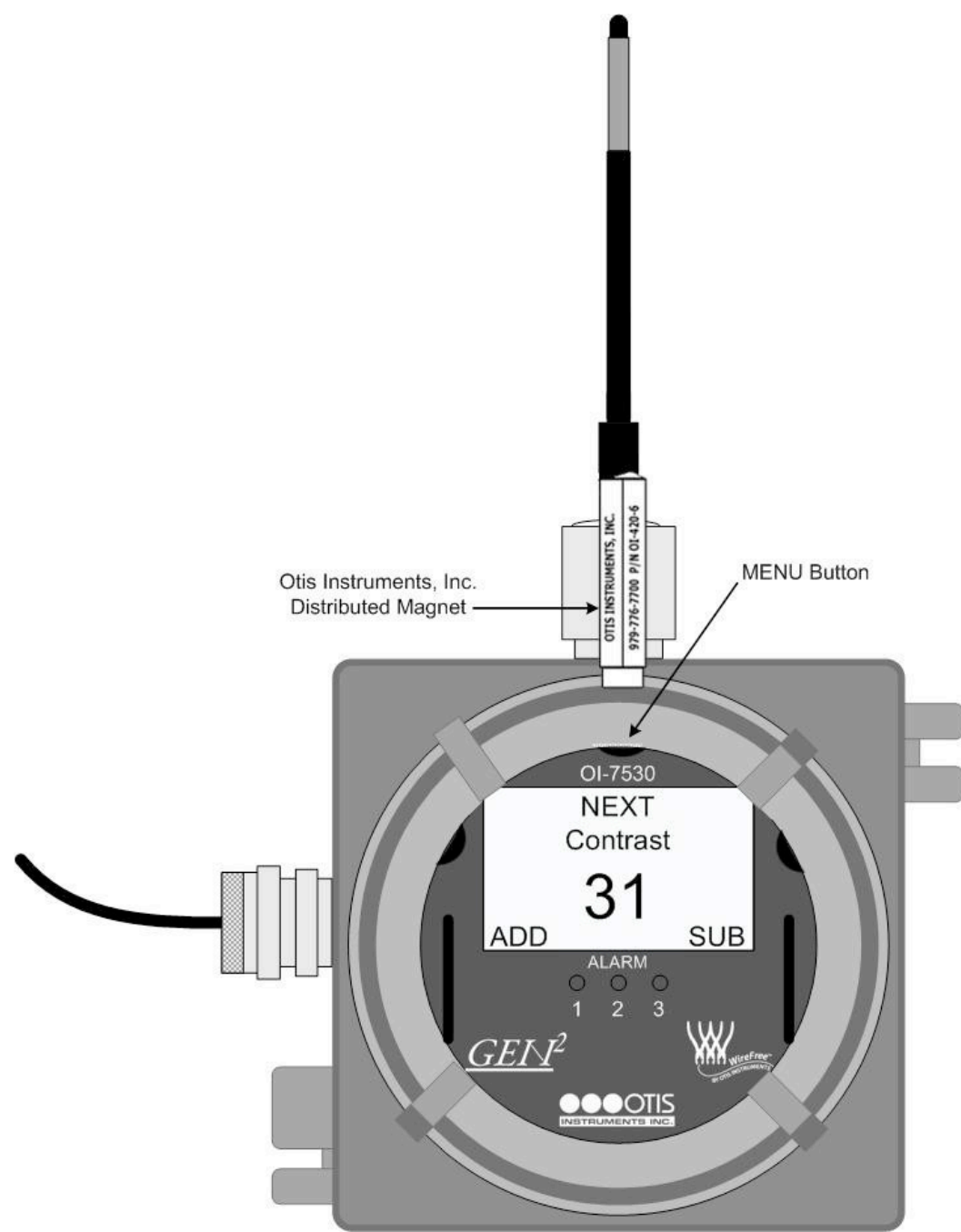

Restore Factory Default Settings

Touch *ADD* or *SUB* (Yes/No—as indicated on the display screen) to set the unit back to the factory's default settings. Touch *MENU* (Next) to confirm the settings.

Factory settings are:

- Channels 1-32 "On"
- All Relays set "On" at 10, 15, 20; Unlatching; Rising
- Channel Addresses set to 1-32
- Contrast set at 31
- Network Channel set to 5
- Secondary Monitor
- Radio Timeout is 10 minutes

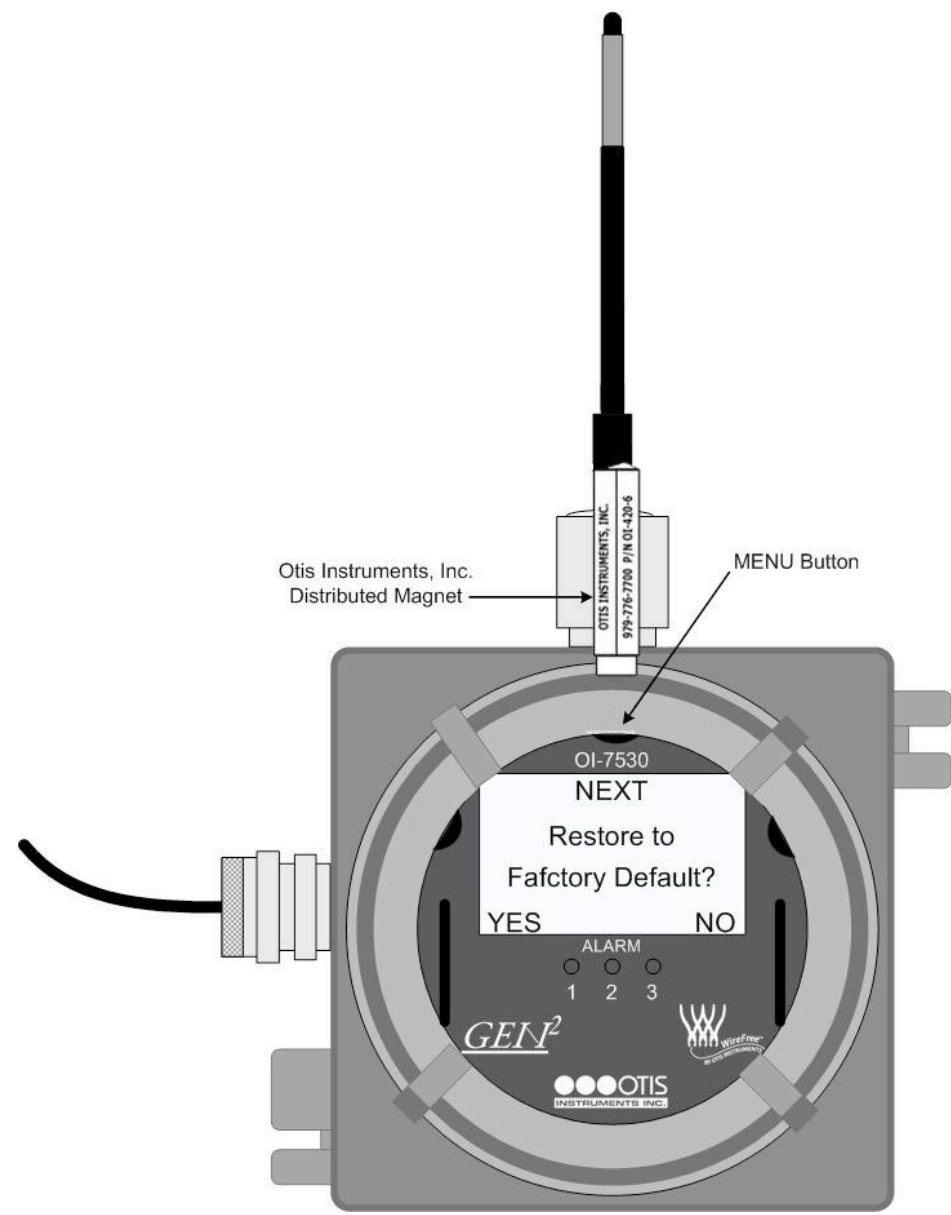

Fault Relay Setup: Relay 3 Fault Relay

Touch *ADD* or *SUB* (Yes/No—as indicated on the display screen) to setup Relay 3 as the Fault Relay. Touch *MENU* (Next) to confirm the setting.

NOTE: With this feature enabled, if any Fault occurs (on any channel) the Fault Relay is engaged. In addition, Relay 3 is removed from all setup options.

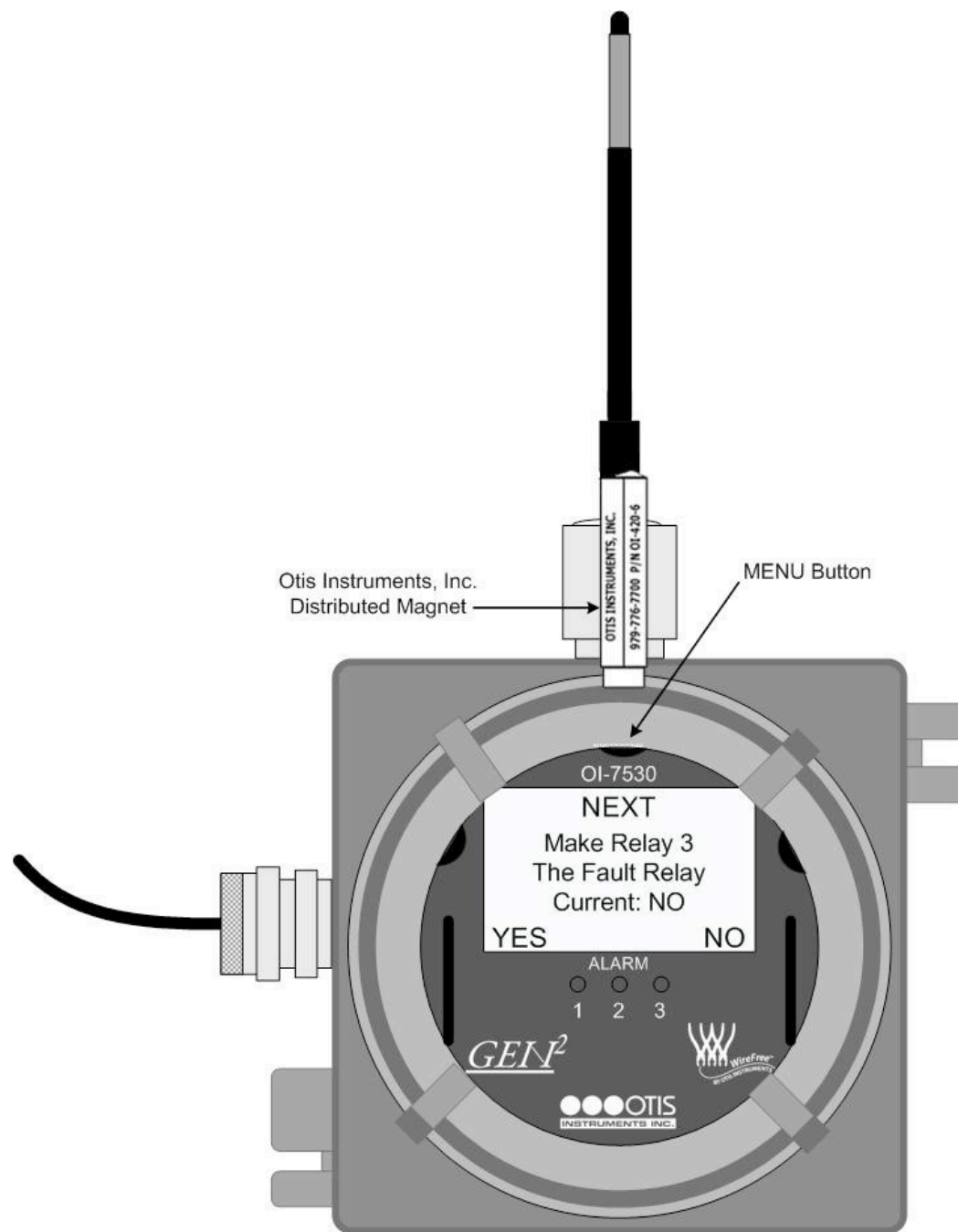

Fault Relay Setup: Latching or Unlatching

NOTE: This option will only appear if "Yes" is chosen on the previous option, setting Relay 3 as a Fault Relay.

Touch *ADD* or *SUB* (Yes/No—as indicated on the display screen) to set Relay 3 as Latching or Unlatching. Touch *MENU* (Next) to confirm the setting.

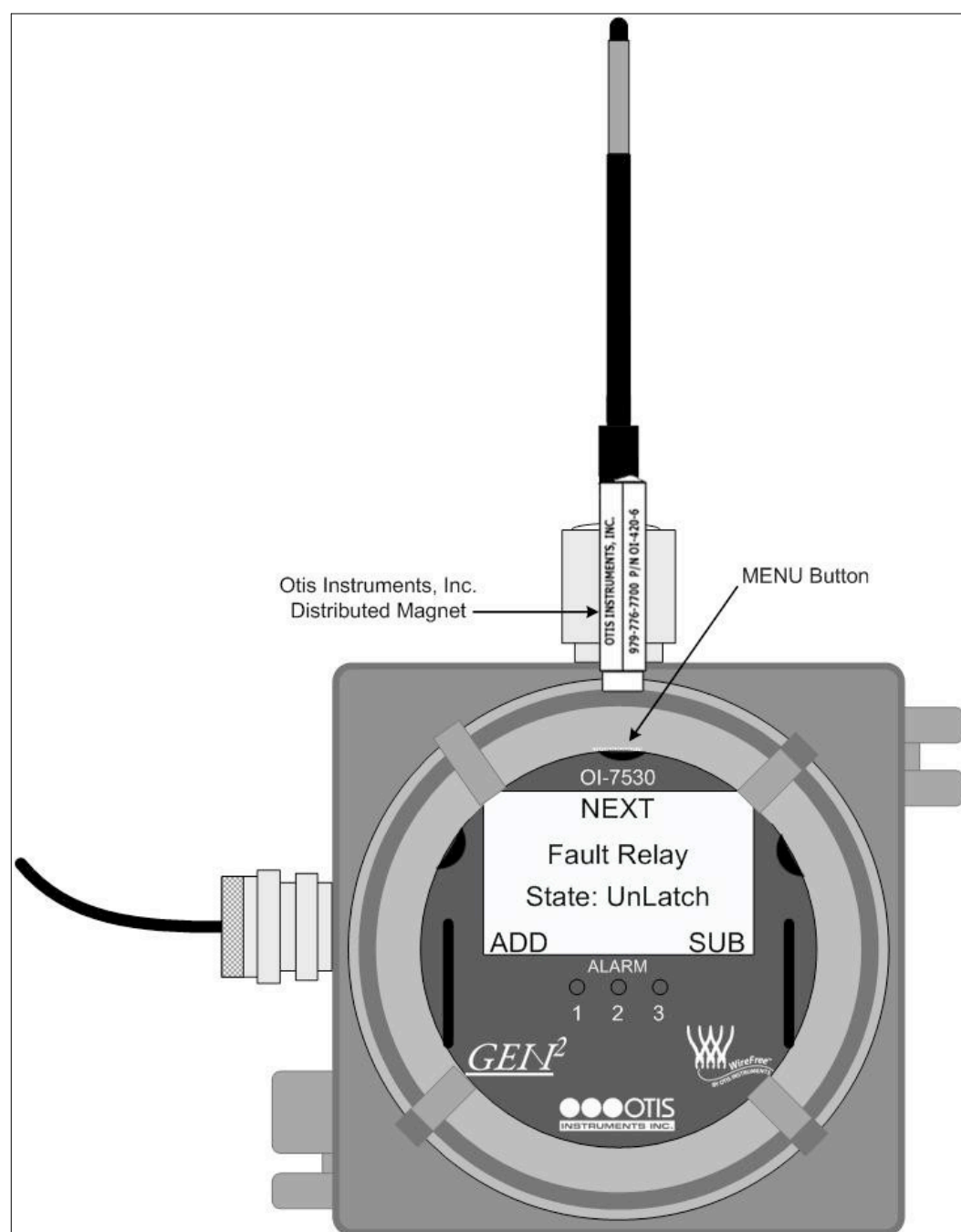

Radio Timeout Setting

Touch *ADD* (increase) or *SUB* (decrease) to manipulate the Radio Timeout Setting. Touch *MENU* (Next) to confirm the setting.

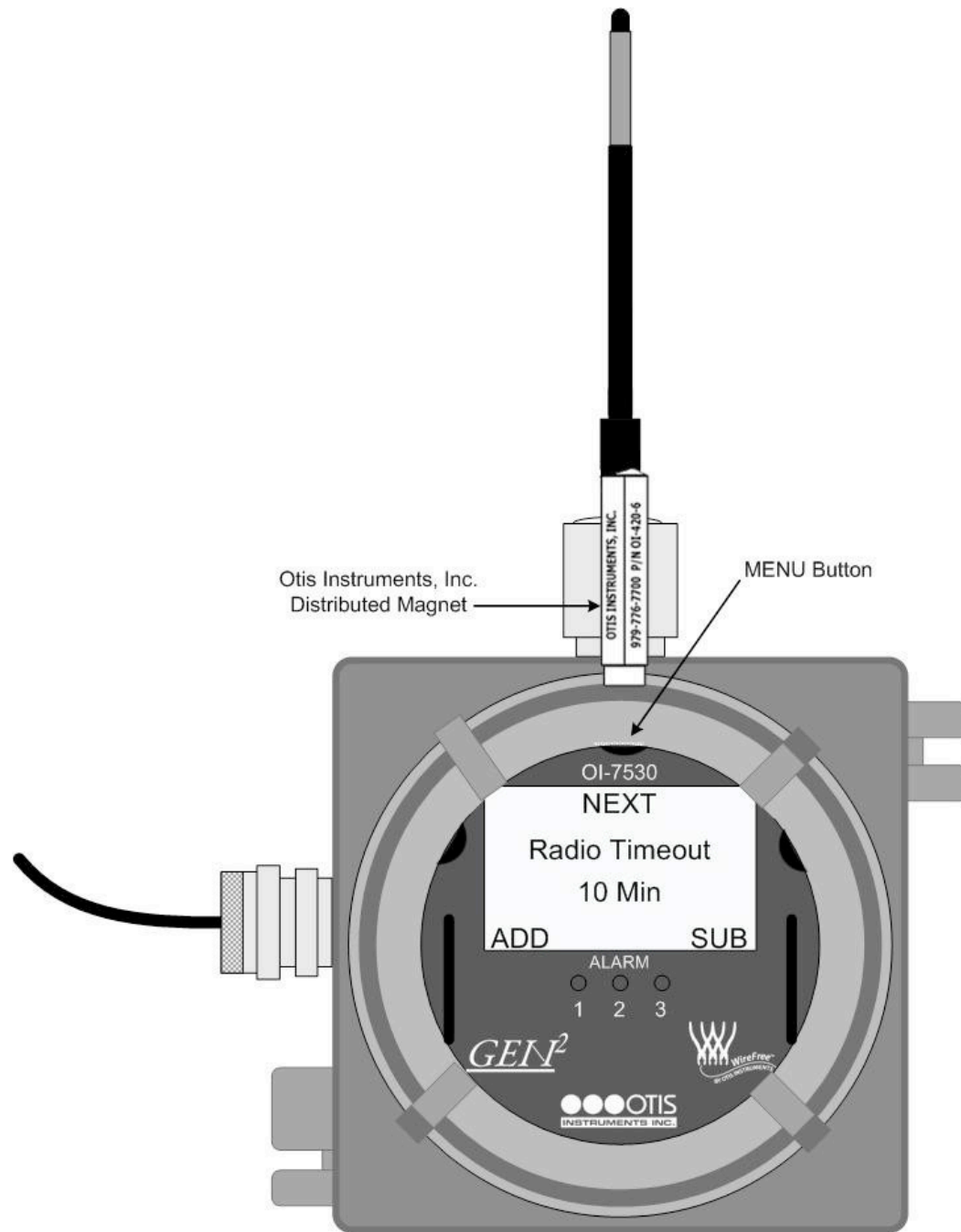

Network Channel Setting

Press *ADD* (increase) or *SUB* (decrease) to manipulate the Network Channel Setting. Touch *MENU* (Next) to confirm the setting.

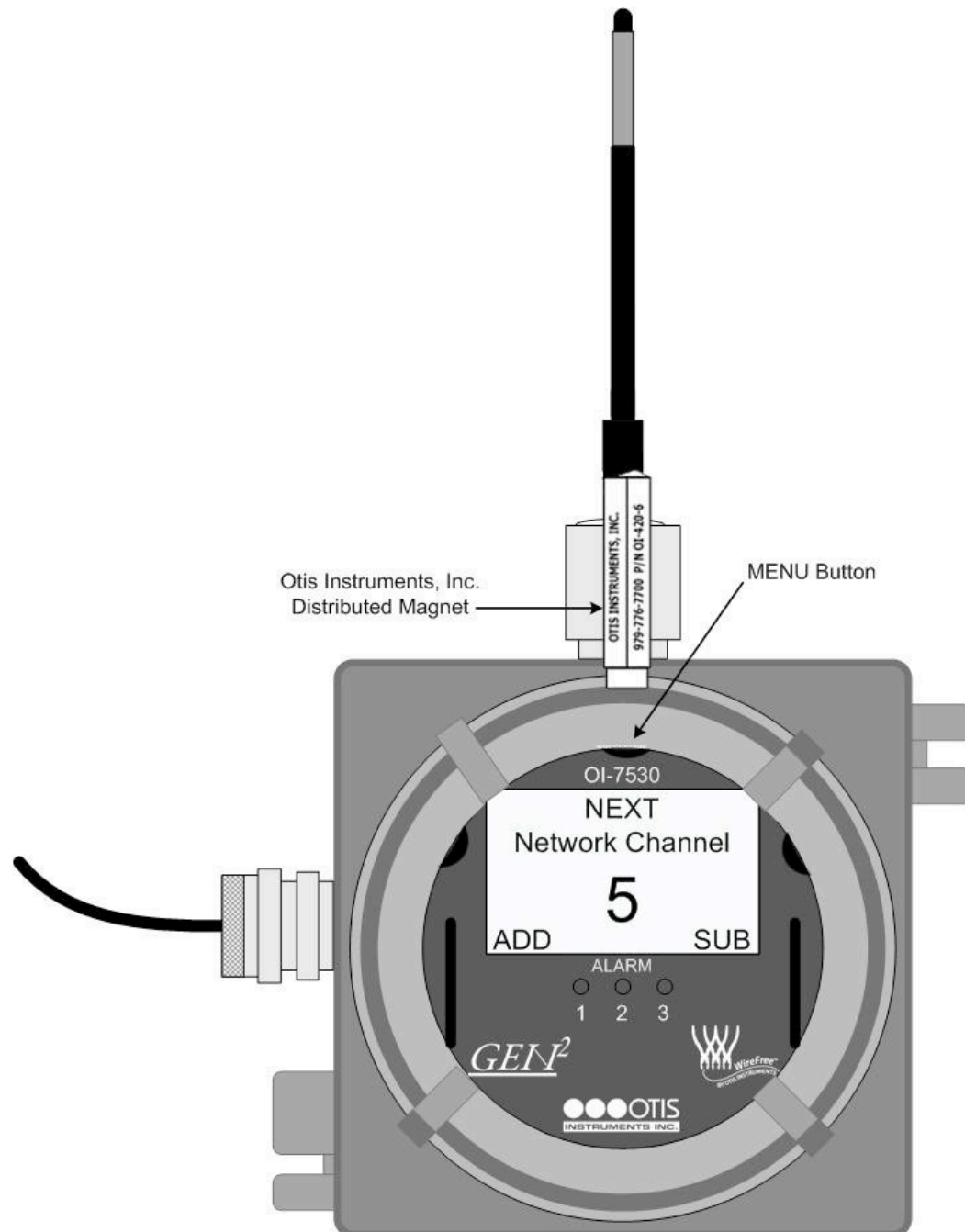

Primary/Secondary Setting

Touch *ADD* (increase) or *SUB* (decrease) to toggle between “Primary” and “Secondary”. Touch *MENU* (Next) to confirm the setting and exit the Advanced Configuration Menu.

NOTE: On each Gen II network there can be only one “Primary” monitor—all other monitors must be setup as “Secondary” monitors.

NOTE: If the OI-7530 is set as a “Secondary” monitor when there is no “Primary” monitor, the OI-7530 will go into Fault 15.

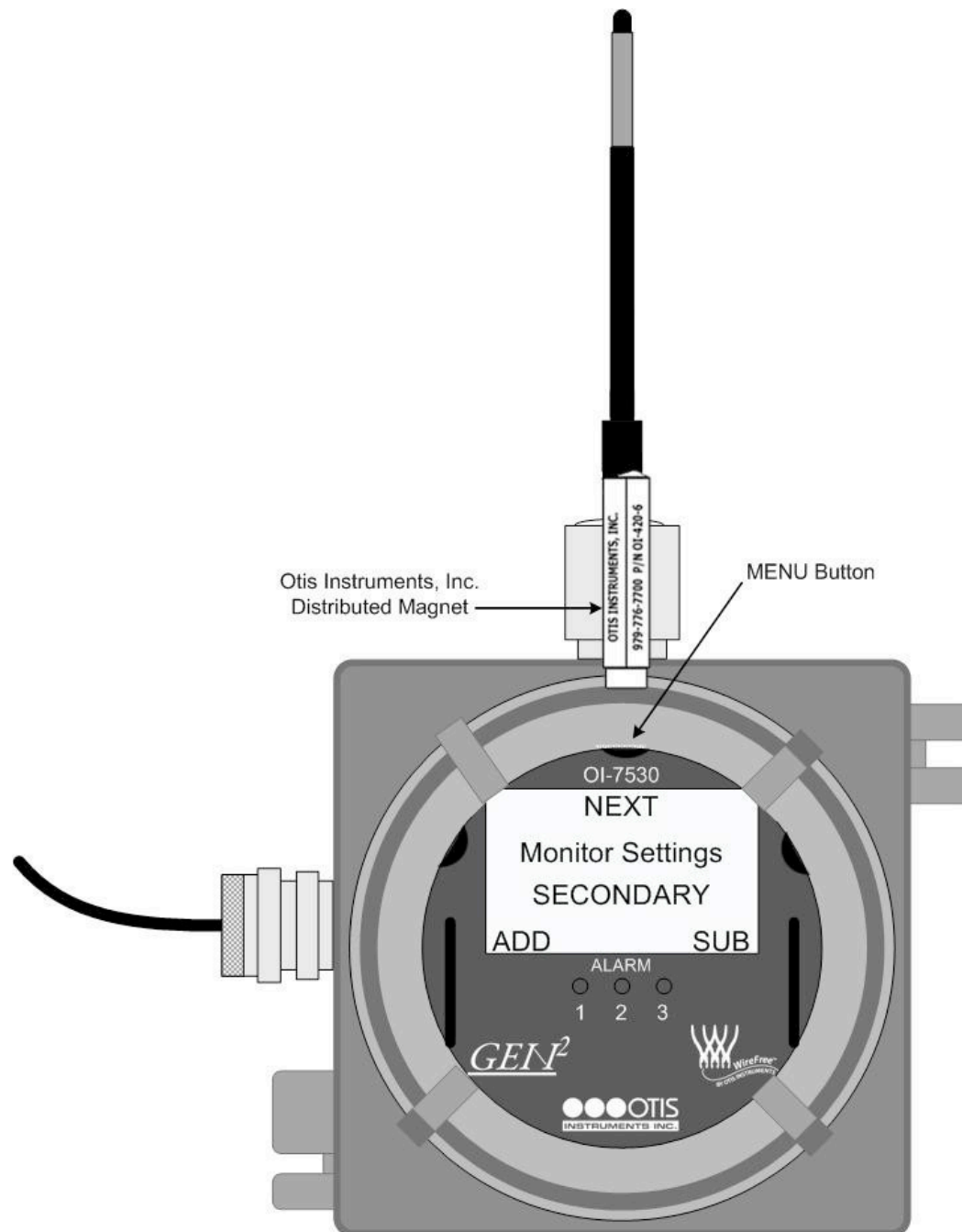

Relay/Alarm Tests

When fully functional the device is able to notify the user of gas presence at the sensor with a low, high, or danger alarm. To ensure that each of these features are working properly, the following tests should be run periodically. If a test is failed, the device may need to be repaired or replaced.

NOTE: Do not open the enclosure while the area is classified as Class I Division 1, or if an explosive gas atmosphere may be present.

Relay 1 (Low Alarm) Test

1. Touch and hold an Otis Instruments, Inc. distributed magnet to *MENU* and *SUB* for five seconds to enter Alarm Test Mode.

NOTE: Continue holding MENU and SUB for the duration of the Relay/Alarm Tests.

2. To pass the Low Alarm Test the device must do the following:

- LED “1” will illuminate
- Any connected alarm will trigger

3. If the system passes the Low Alarm Test, proceed to the next test.

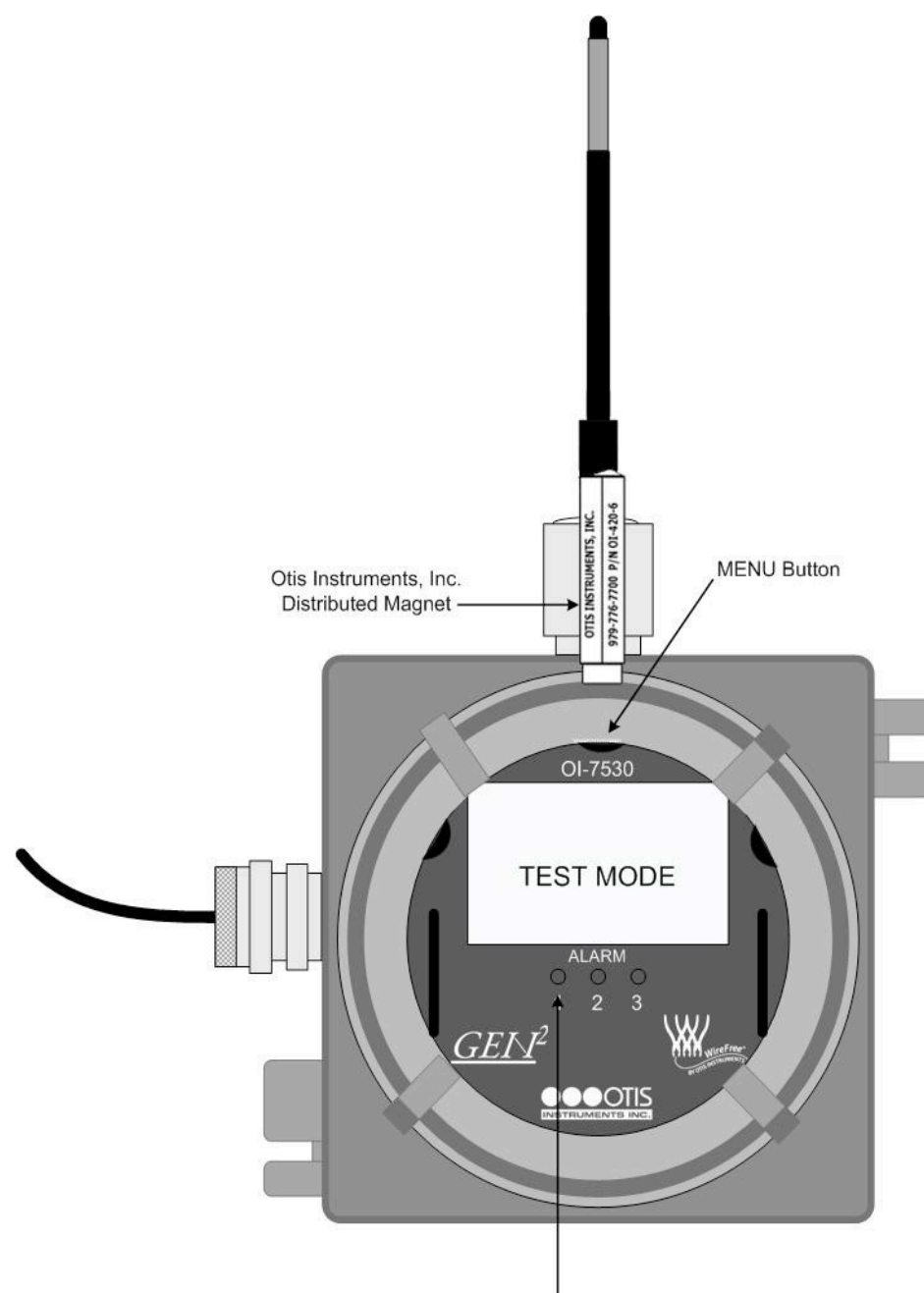

Relay 2 (High Alarm) Test

1. Continue holding the magnet to *MENU* and *SUB* for an additional five seconds.
2. To pass the High Alarm Test the device must do the following:
 - LED "2" will illuminate
 - Any connected alarm will trigger
3. If the system passes the High Alarm Test, proceed to the next test.

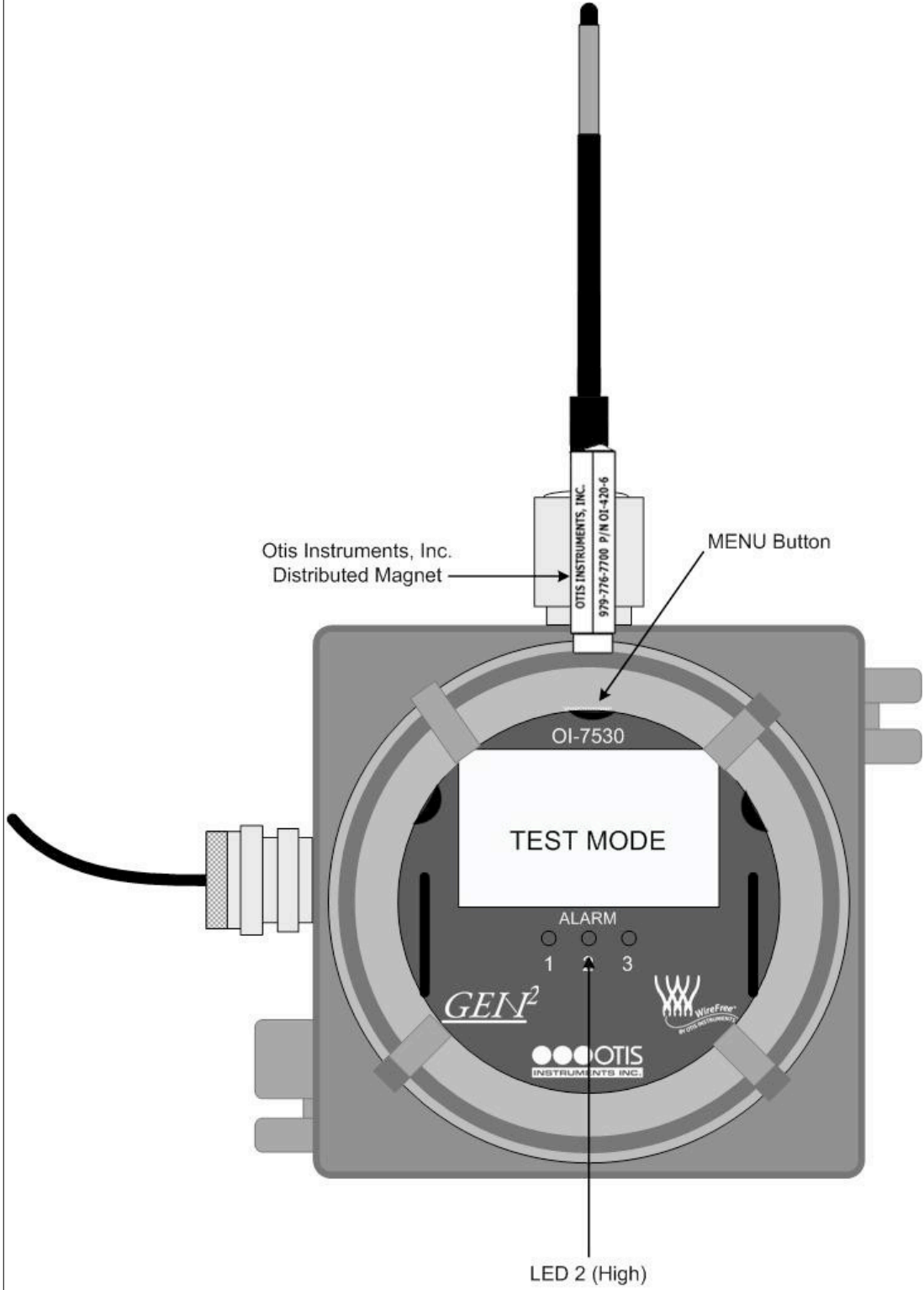

Relay 3 (Danger Alarm) Test

1. Continue holding the magnet to *MENU* and *SUB* for an additional five seconds.
2. To pass the Danger Alarm Test the device must do the following:
 - LED "3" will illuminate
 - Any connected alarm will trigger
3. Once the Danger Alarm Test is complete, release the magnet from *MENU* and *SUB*, then touch the magnet to *MENU* again to exit Alarm Test Mode.

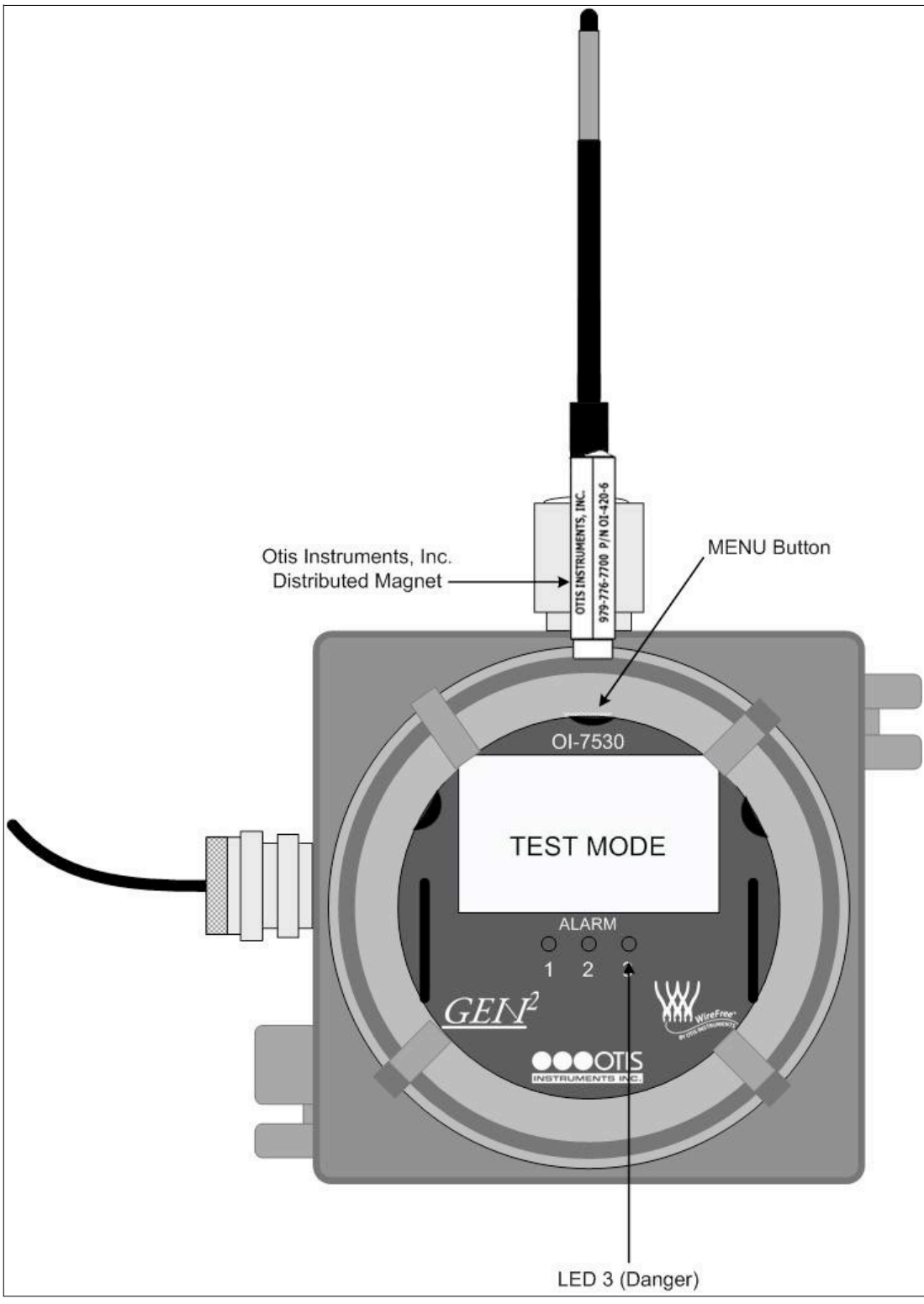

Antenna Replacement

The antenna is used to aid in receiving clear and reliable radio signals from the sensors. The current antenna can be replaced with any Otis Instruments supplied antenna that is compatible with the radio frequency and antenna fitting on the enclosure.

NOTE: Do not open the enclosure while the area is classified as Class I Division 1, or if an explosive gas atmosphere may be present.

1. Power off the device by turning off the voltage supply at the power source (DC power), or by unplugging the unit (AC power).
2. Unscrew the current Antenna at the Antenna Fitting located on the device.
3. Screw the new Antenna onto the Antenna Fitting.
4. Supply power to the unit to return to Normal Operating Mode.

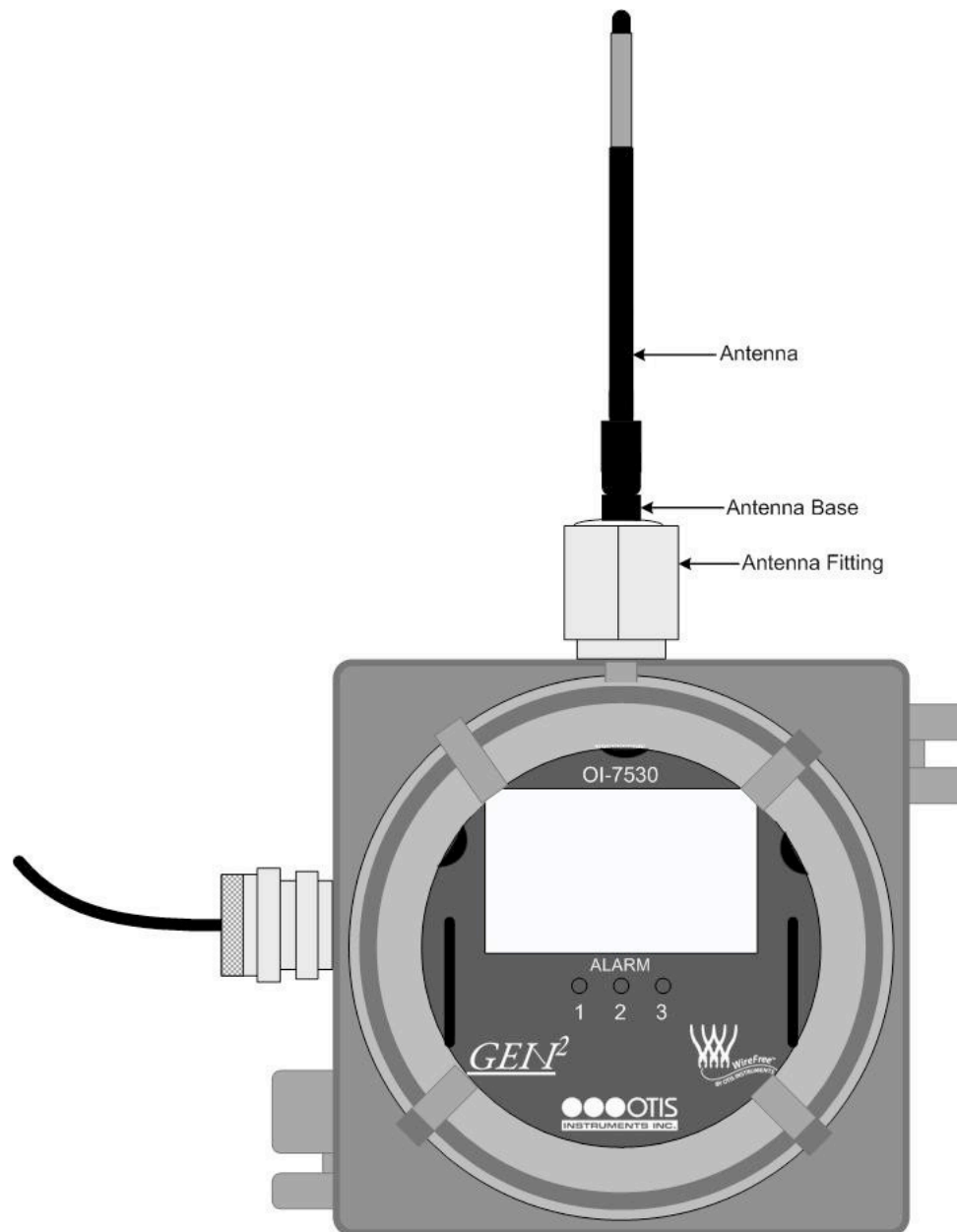

APPENDIX A: AC Wiring Configurations



CAUTION: THE INTERNAL COMPONENTS CAN BE STATIC SENSITIVE. USE CAUTION WHEN OPENING THE ENCLOSURE AND HANDLING INTERNAL COMPONENTS.

AC Wiring Configurations

To ensure full-functionality, complete ALL of the following Wiring Configurations before installing the device in the field. *Please read all of the following items BEFORE wiring the device:*

- The relay outputs are Dry Contacts. The following relay wiring configurations are one example of a common wiring scenario. Wiring choices for certain applications may differ from what is described in this Operation Manual.
- Verify that there is no power being sent from the power supply while wiring the relays.
- Otis Instruments, Inc. recommends wiring the relays as “NO” for most applications. With a “NO” relay, the relay will only be triggered if gas is seen.
- The user may choose to wire the relays as “NC” if desired. To do so, connect the neutral wire from the power supply to the terminal labeled “NC” (Normally Closed) instead of the terminal labeled “NO” (Normally Open).
- The wire colors used in the following drawings are used for ease of displaying which wires go where. Although the wire colors used in these drawings are standard colors, not all applications will use the same wire colors.
- To ensure technician safety, always wire the relays BEFORE supplying power to the device.
- For optimal performance, the manufacturer recommends using a minimum of 22 gauge wire for all Wiring Configurations. Different loads require different gauge wire. Use appropriate wire size, depending on the voltage and current requirements.

AC Power Supply Wiring Configurations

NOTE: The unit will be wired for the power-type that is requested by the purchaser when shipped from Otis Instruments, Inc.

NOTE: To ensure technician safety, always wire the relays BEFORE supplying power to the device.

1. Locate the “12 to 35VDC” Terminal Block on the back of the Terminal Board.
2. Locate the DC Power Terminal Block and AC Power Terminal Block (on the metal “X”) inside the enclosure.

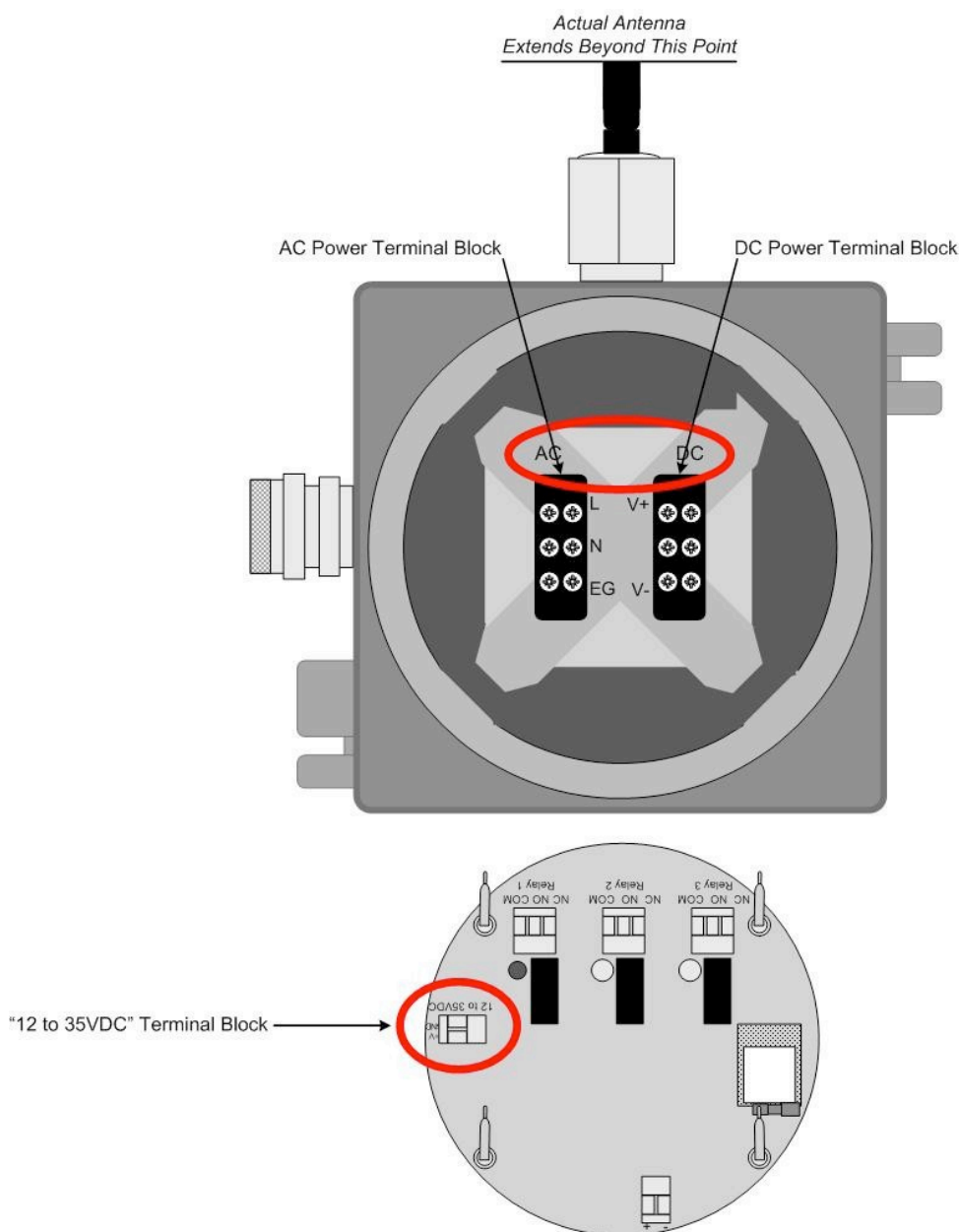

3. Connect a positive wire (red) to the terminal labeled “+V” on the Terminal Board’s “12 to 35VDC” Terminal Block.
4. Connect the other end of that same positive wire (red) from the Terminal Board to the terminal labeled “V+” on the internal DC Power Terminal Block.
5. Connect a neutral wire (black) from the terminal labeled “GND” on the Terminal Board’s “12 to 35VDC” Terminal Block.
6. Connect the other end of that same neutral wire (black) from the Terminal Board to the terminal labeled “V-” on the internal DC Power Terminal Block.

The following items are pre-wired at the factory before assembly is complete. These descriptions are for informative purposes only, and should not be modified.

7. There will be a positive wire (red) pre-wired from the AC Power Supply to the terminal labeled “V+” on the internal DC Power Terminal Block.
8. There will be a neutral wire (black) pre-wired from the AC Power Supply to the terminal labeled “V-” on the internal DC Power Terminal Block.
9. There will be three wires (black, white and green) pre-wired from the Delta power supply terminals to the internal AC Power Block terminals labeled: “L” (AC Load IN), “N” (AC Neutral IN), and “EG” (Chassis GND or Earth GND). This set of wires will be used to plug into an AC power outlet ONCE ALL WIRING CONFIGURATIONS ARE COMPLETE.

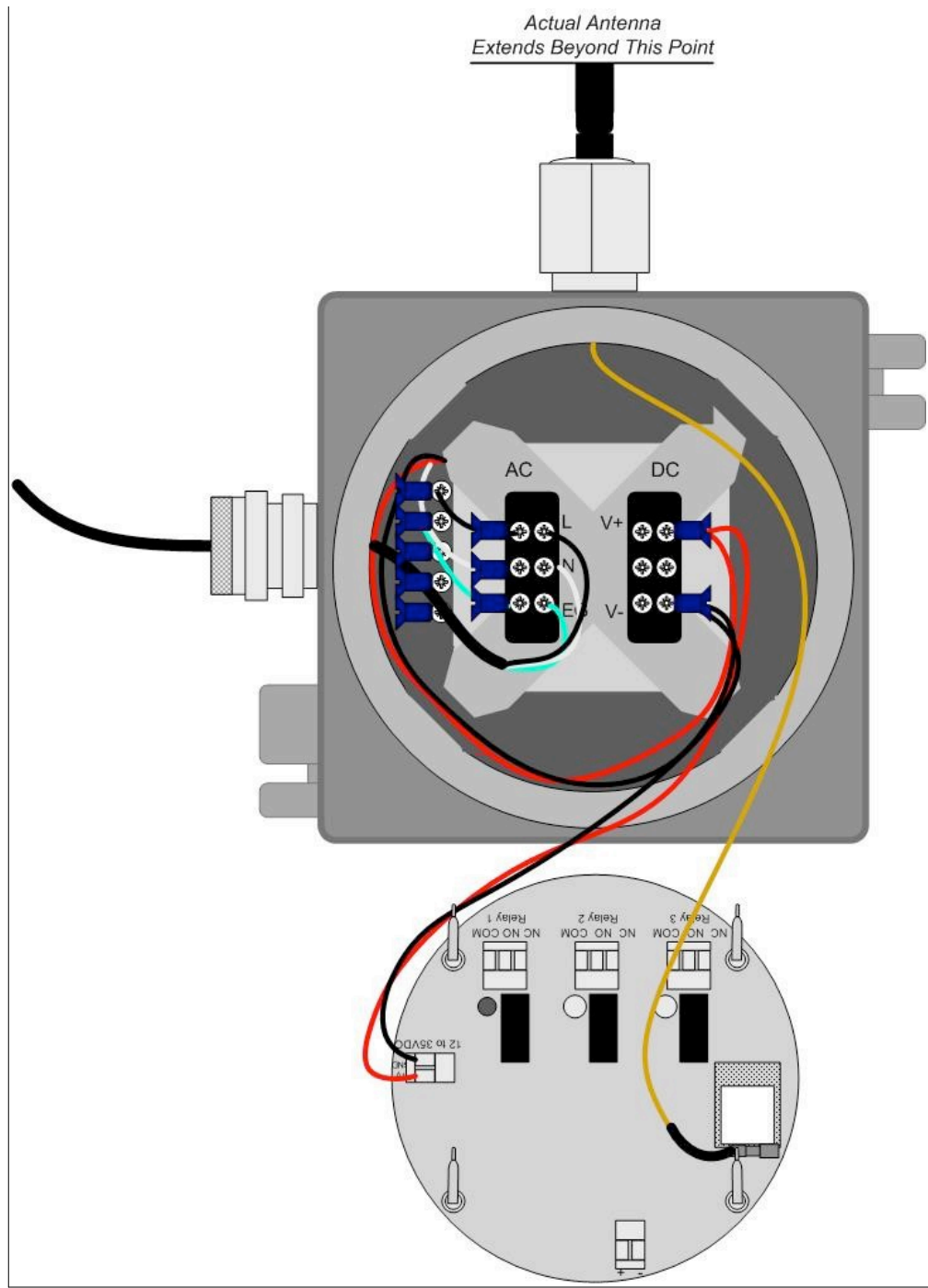

Relay 1 (Low Alarm) Wiring Configurations

1. Unscrew, remove and set aside the explosion proof lid.
2. Using the handles on the Front Panel, lift the Front Panel completely out of the enclosure to expose the terminals on the back side of the Terminal Board.

NOTE: Do not use any metal object to remove the Front Panel from the enclosure.

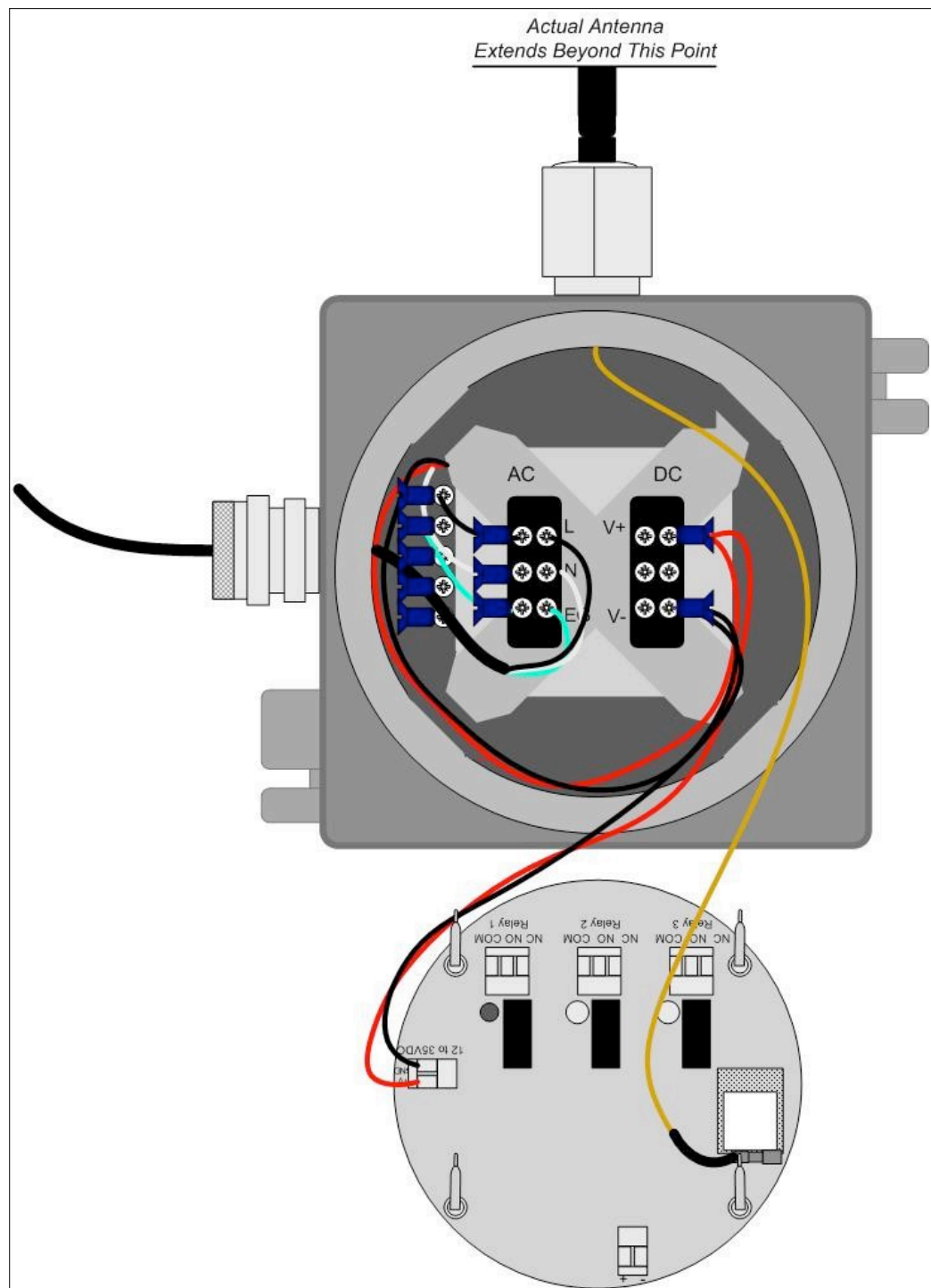

3. Locate the Relay 1 terminal block on the back of the Terminal Board.
4. Bring the two conductor cables from the Low Alarm to the OI-7500 using the proper certified 3/4" NPT cable gland or conduit fitting.
5. Run the two conductor cables for Relay 1 from the Low Alarm through the hub on the OI-7530 Enclosure.
6. Connect a positive wire (red) from the terminal labeled "V+" on the Terminal Board's "12 to 35VDC" Terminal Block to the terminal labeled "COM" on the Relay 1 Terminal Block.
7. Connect the positive wire (red) from the Low Alarm to the terminal labeled "NO" on the Relay 1 Terminal Block.
8. Connect the neutral wire (black) from the Low Alarm to the terminal labeled "V-" on the internal DC Power Terminal Block.
9. Once the Relay 1 Wiring Configurations are complete, proceed to the next section.

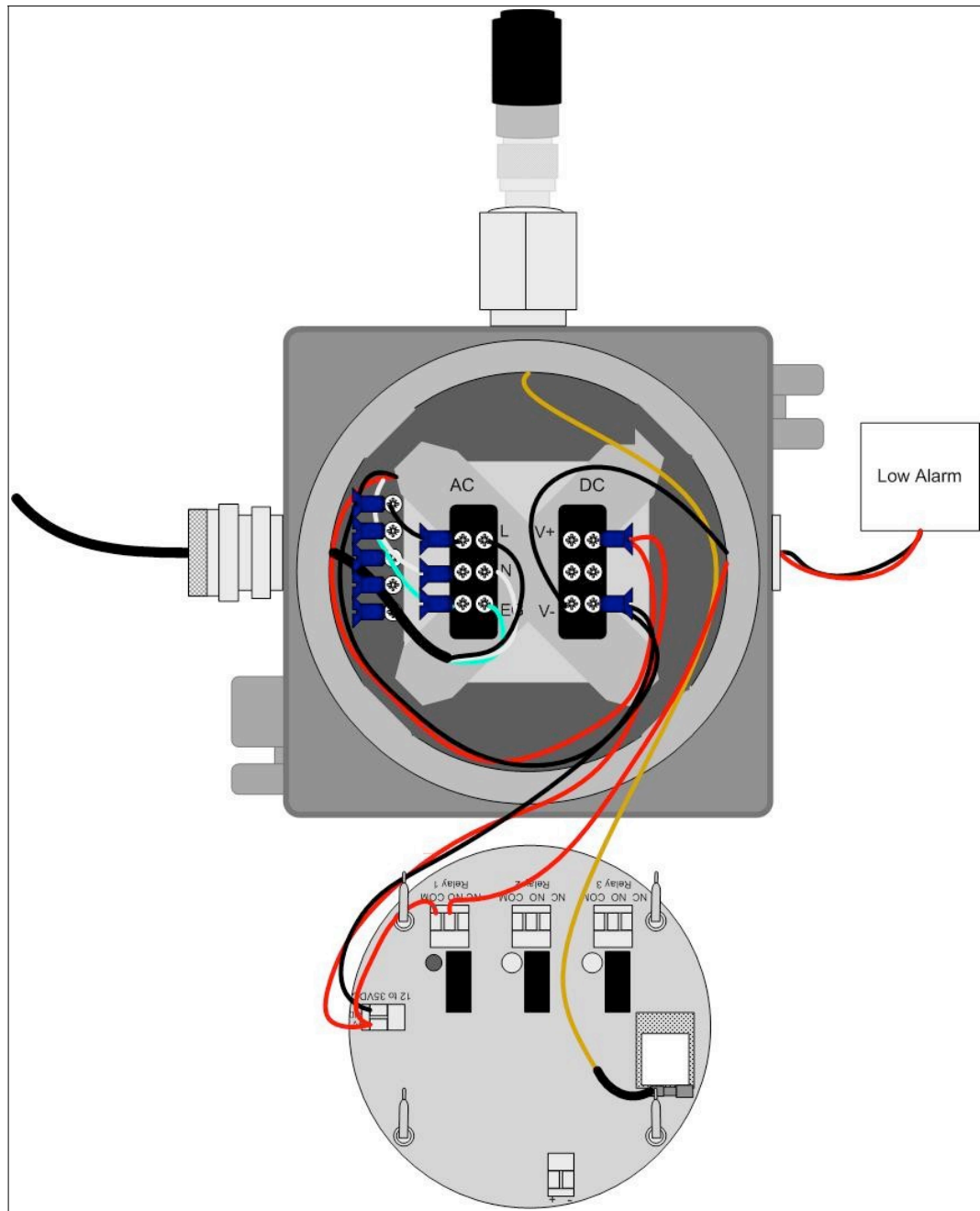
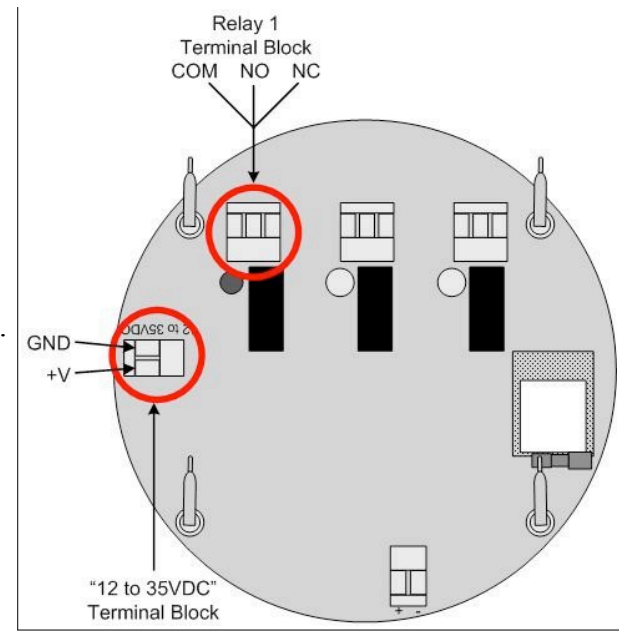

Relay 2 (High Alarm) Wiring Configurations

1. After the Relay 1 Wiring Configurations have been completed (see previous section), locate the Relay 2 terminal block on the back of the Terminal Board.
2. Bring the two conductor cables from the High Alarm to the OI-7530 using the proper certified 3/4" NPT cable gland or conduit fitting.
3. Run the two conductor cables for Relay 2 from the High Alarm through the hub on the OI-7530 Enclosure.
4. Connect a jumper wire (blue) from the terminal labeled "COM" on the Relay 1 Terminal Block to the terminal labeled "COM" on the Relay 2 Terminal Block.
5. Connect the positive wire (red) from the High Alarm to the terminal labeled "NO" on the Relay 2 Terminal Block.
6. Connect the neutral wire (black) from the High Alarm to the terminal labeled "V-" on the internal DC Power Terminal Block.
7. Once the Relay 2 Wiring Configurations are complete, proceed to the next section.

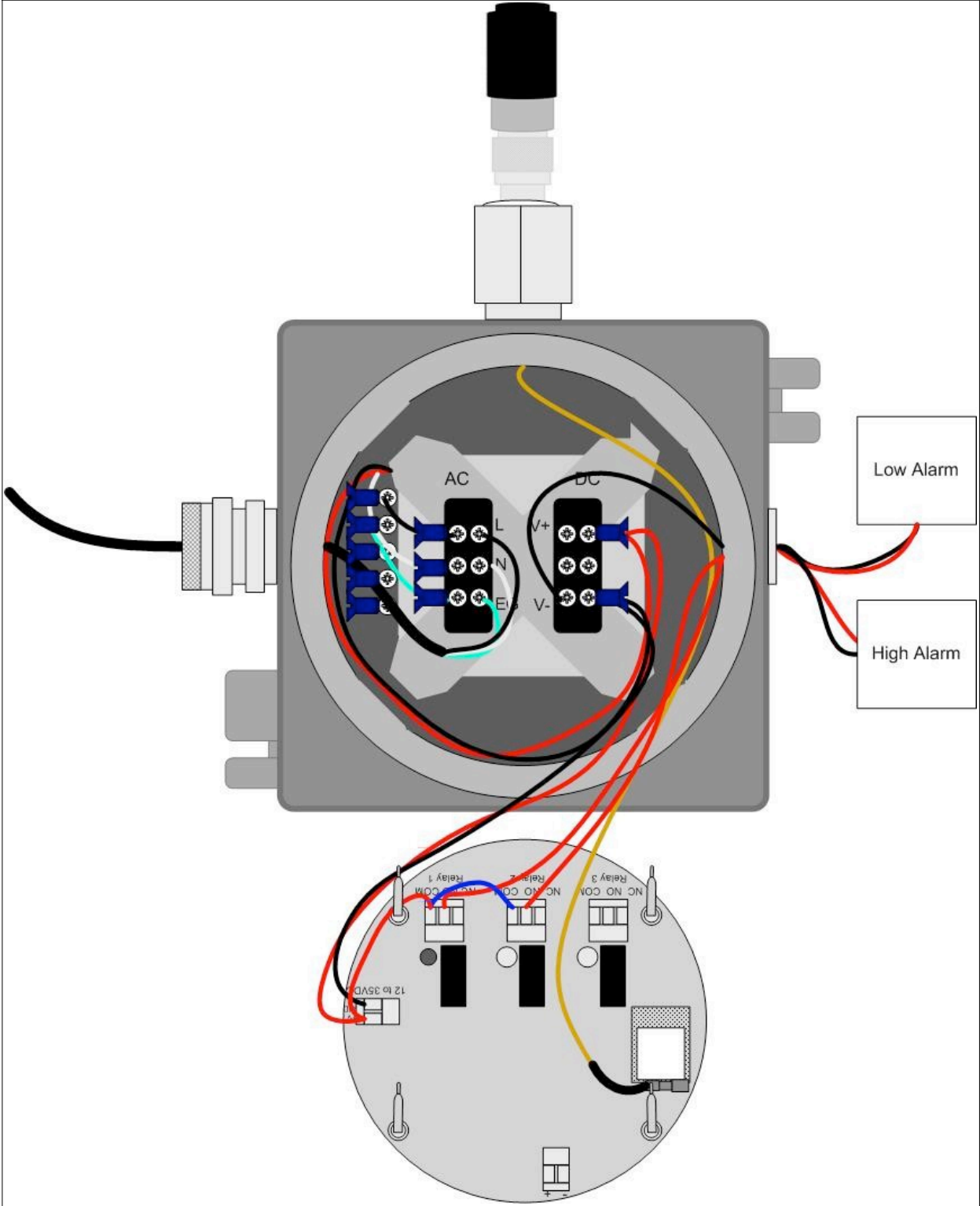
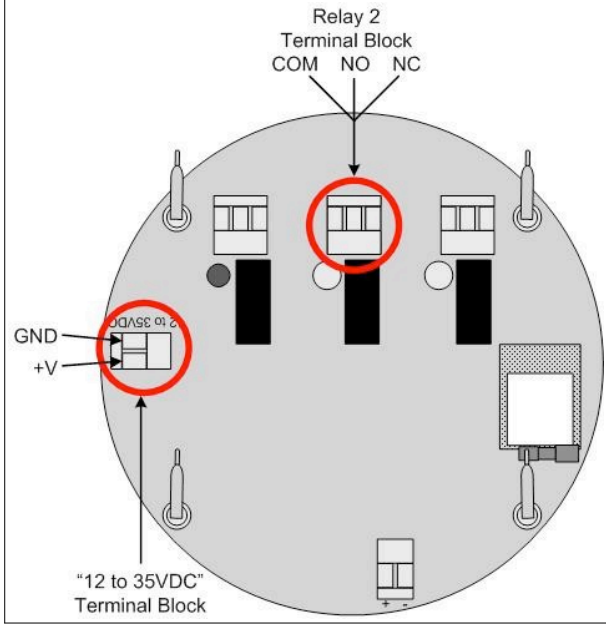

Relay 3 (Danger Alarm) Wiring Configurations

1. After the Relay 2 Wiring Configurations have been completed (see previous section), locate the Relay 3 terminal block on the back of the Terminal Board.
2. Bring the two conductor cables from the Danger Alarm to the OI-7530 using the proper certified 3/4" NPT cable gland or conduit fitting.
3. Run the two conductor cables for Relay 3 from the Danger Alarm through the hub on the OI-7530 Enclosure.
4. Connect a jumper wire (blue) from the terminal labeled "COM" on the Relay 2 Terminal Block to the terminal labeled "COM" on the Relay 3 Terminal Block.
5. Connect the positive wire (red) from the Danger Alarm to the terminal labeled "NO" on the Relay 3 Terminal Block.
6. Connect the neutral wire (black) from the Danger Alarm to the terminal labeled "V-" on the internal DC Power Terminal Block.
7. Replace the Control Board and attached components into the enclosure by matching each of the mounting posts to its corresponding receptacle inside the enclosure.

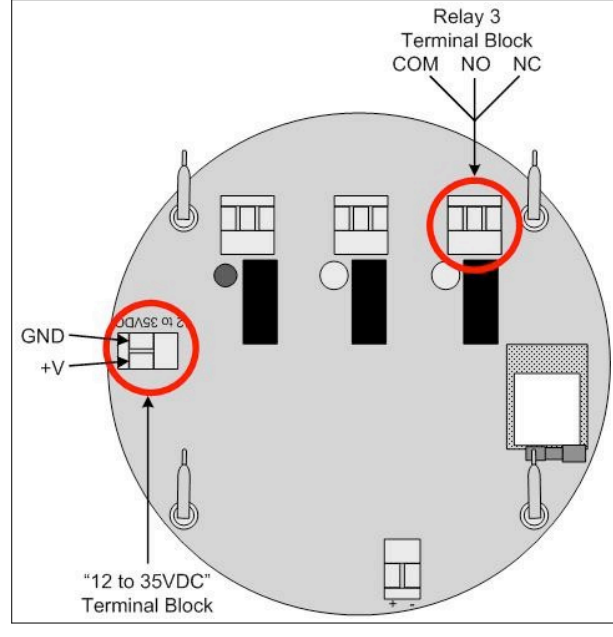

NOTE: When replacing the boards back in the enclosure, be careful not to disturb or remove any of the wires that were just configured.

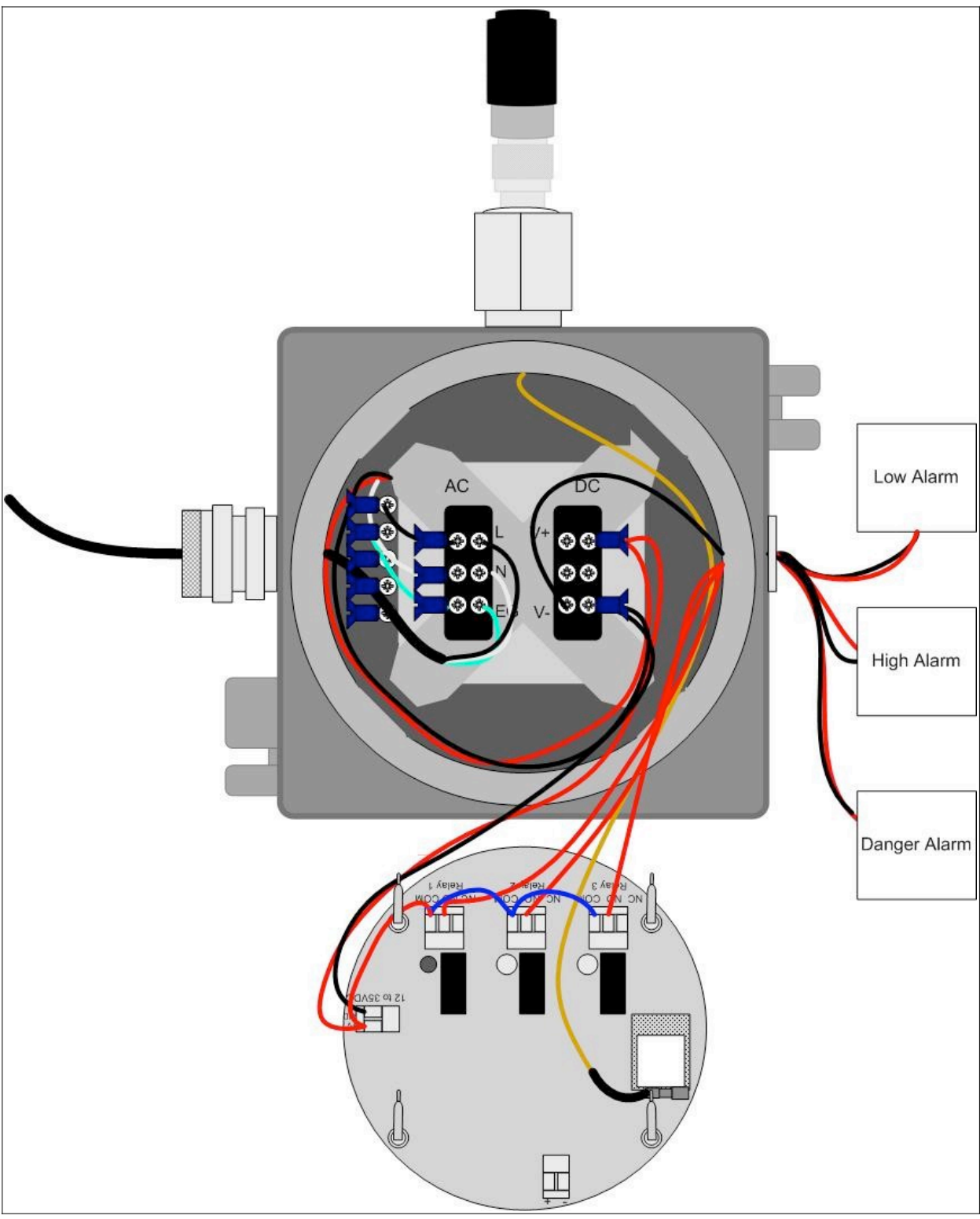

8. Verify that each mounting post is properly fitted in its corresponding receptacle inside the enclosure.
9. Place the enclosure lid on top of the enclosure base.
10. Rotate the lid until it is tightly screwed in place (approximately 20 rotations).
11. All AC Wiring Configurations are complete. Once power is supplied, the device will be fully functional and ready to operate.

Shown Above: AC Wiring Configurations – Complete Wiring Diagram (power and all three relays connected).

APPENDIX B: DC Wiring Configurations



CAUTION: THE INTERNAL COMPONENTS CAN BE STATIC SENSITIVE. USE CAUTION WHEN OPENING THE ENCLOSURE AND HANDLING INTERNAL COMPONENTS.

DC Wiring Configurations

To ensure full-functionality, complete ALL of the following Wiring Configurations before installing the device in the field. *Please read all of the following items BEFORE wiring the device:*

- The relay outputs are Dry Contacts. The following relay wiring configurations are one example of a common wiring scenario. Wiring choices for certain applications may differ from what is described in this Operation Manual.
- Verify that there is no power being sent from the power supply while wiring the relays.
- Otis Instruments, Inc. recommends wiring the relays as “NO” for most applications. With a “NO” relay, the relay will only be triggered if gas is seen.
- The user may choose to wire the relays as “NC” if desired. To do so, connect the neutral wire from the power supply to the terminal labeled “NC” (Normally Closed) instead of the terminal labeled “NO” (Normally Open).
- The wire colors used in the following drawings are used for ease of displaying which wires go where. Although the wire colors used in these drawings are standard colors, not all applications will use the same wire colors.
- To ensure technician safety, always wire the relays BEFORE supplying power to the device.
- For optimal performance, the manufacturer recommends using a minimum of 22 gauge wire for all Wiring Configurations. Different loads require different gauge wire. Use appropriate wire size, depending on the voltage and current requirements.

DC Power Supply Wiring Configurations

NOTE: The unit will be wired for the power-type that is requested by the purchaser when shipped from Otis Instruments, Inc.

NOTE: To ensure technician safety, always wire the relays BEFORE supplying power to the device.

1. Locate the “12 to 35VDC” Terminal Block on the back of the Terminal Board.
2. Locate the DC Power Terminal Block (on the metal “X”) inside the enclosure.

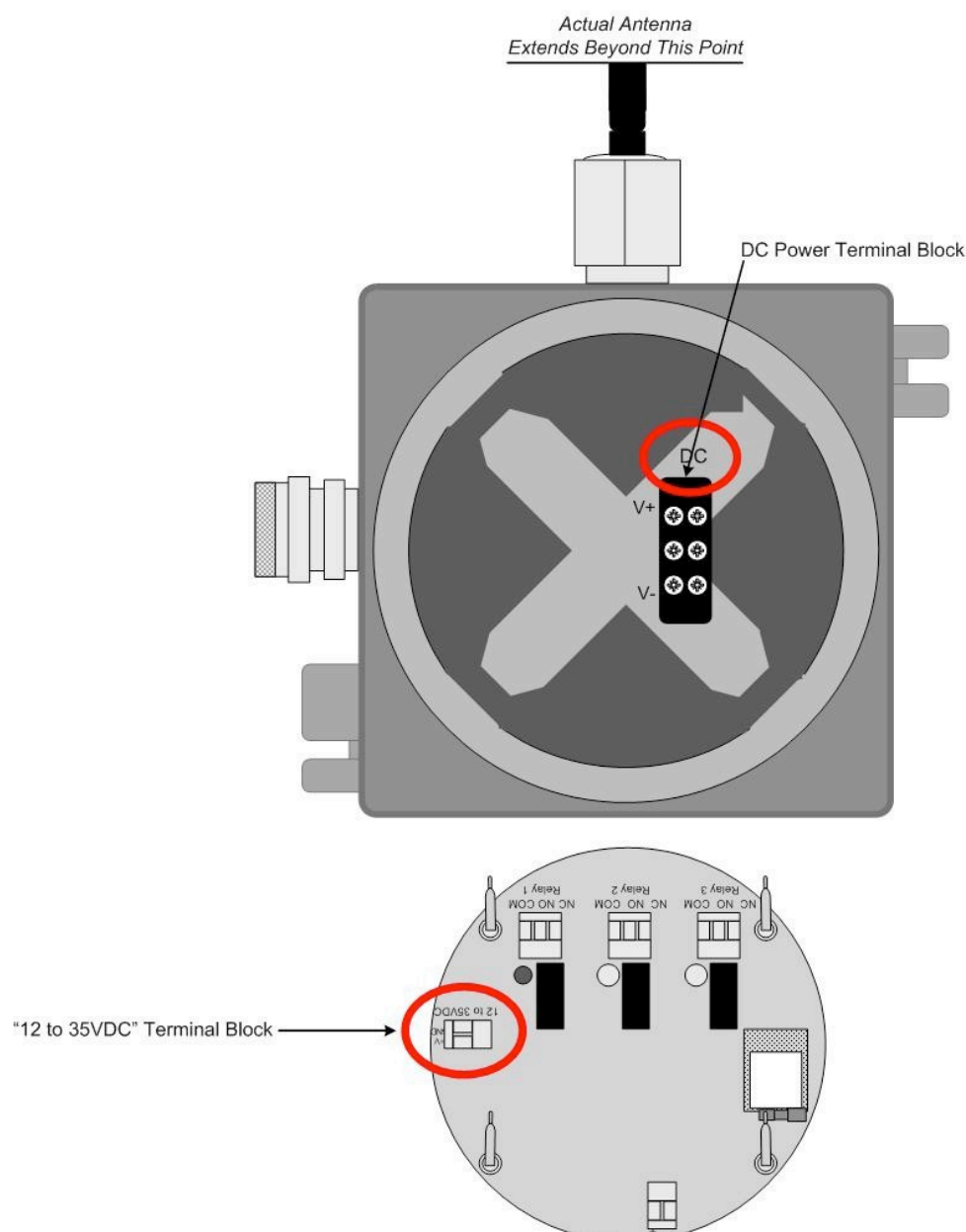

3. Connect a positive wire (red) from the internal DC Power Terminal Block labeled “V+”.
4. Connect the other end of the same positive wire (red) to the terminal labeled “+V” on the Terminal Board's “12 to 35VDC” Terminal Block.
5. Connect a neutral wire (black) from the internal DC Power Terminal Block labeled “V-”.
6. Connect the other end of the same neutral wire (black) to the terminal labeled “GND” on the Terminal Board's “12 to 35VDC” Terminal Block.
7. Connect a positive wire (red) from the internal DC Power Terminal Block to the DC Power Source.
8. Connect a neutral wire (black) from the internal DC Power Terminal Block to the DC Power Source.

NOTE: The left-side hub may be used to run the wires out of the enclosure, as shown in the illustration above.

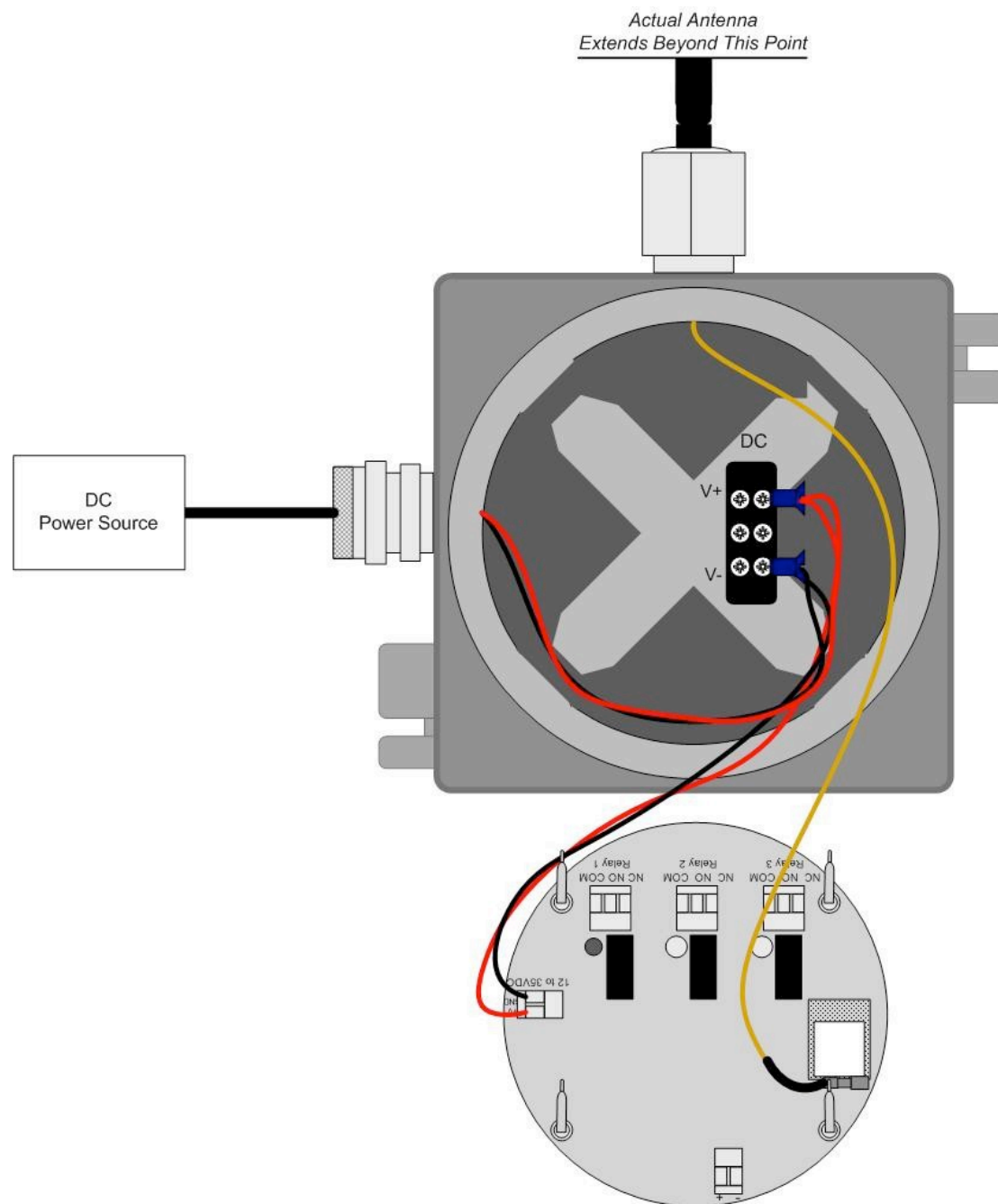

Relay 1 (Low Alarm) Wiring Configurations

1. Unscrew, remove and set aside the explosion proof lid.
2. Using the handles on the Front Panel, lift the Front Panel completely out of the enclosure to expose the terminals on the back of the Control Board.

NOTE: Do not use any metal object to remove the Front Panel from the enclosure.

3. Locate the Relay 1 terminal block on the back of the Terminal Board.
4. Bring the two conductor cables from the Low Alarm to the OI-7530 using the proper certified 3/4" NPT cable gland or conduit fitting.
5. Run the two conductor cables for Relay 1 from the Low Alarm through the hub on the OI-7530 Enclosure.
6. Connect a positive wire (red) from the terminal labeled "V+" on the Terminal Board's "12 to 35VDC" Terminal Block to the terminal labeled "COM" on the Relay 1 Terminal Block.
7. Connect the positive wire (red) from the Low Alarm to the terminal labeled "NO" on the Relay 1 Terminal Block.
8. Connect the neutral wire (black) from the Low Alarm to the terminal labeled "V-" on the internal DC Power Terminal Block.
9. Once the Relay 1 Wiring Configurations are complete, proceed to the next section.

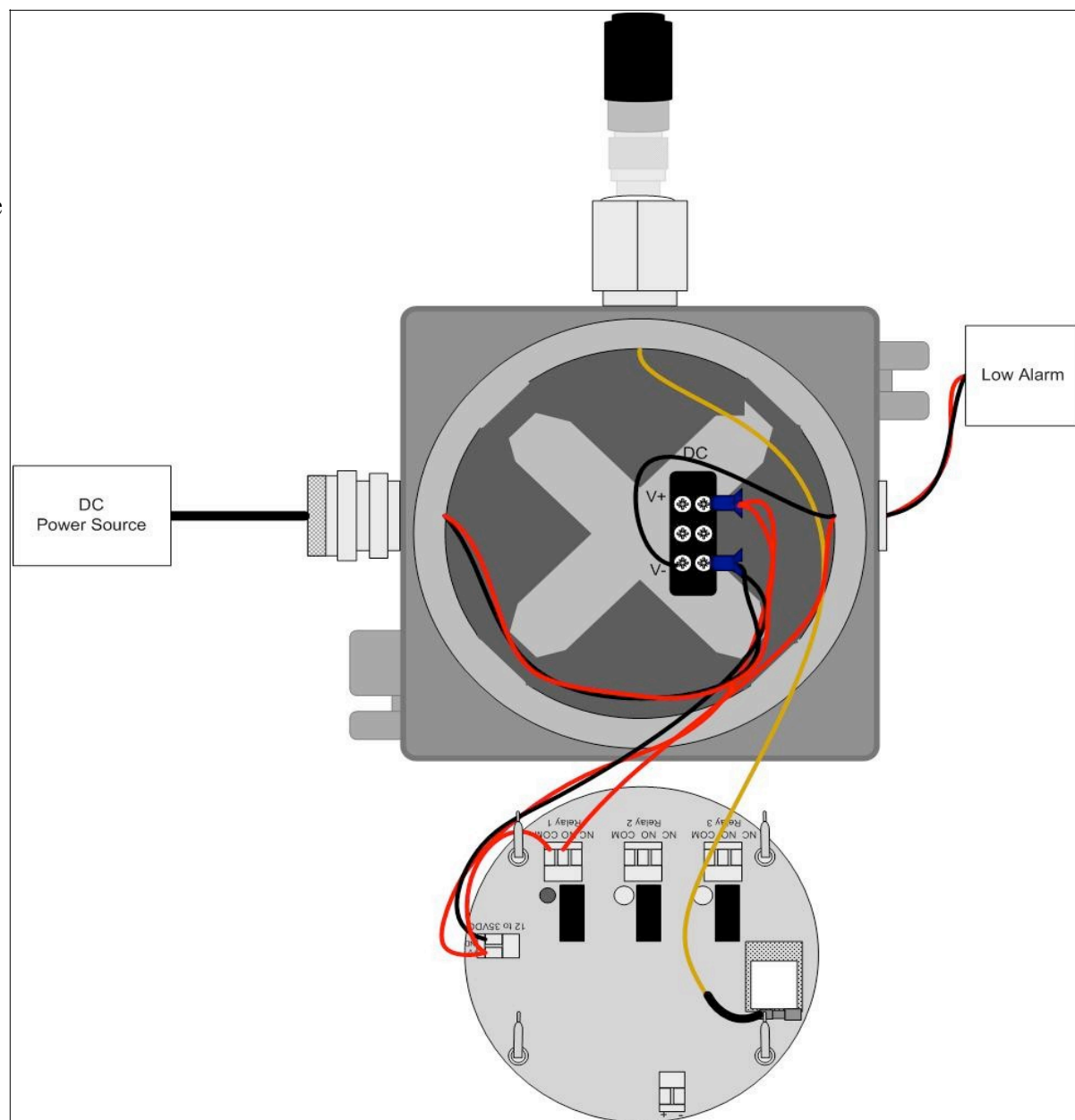
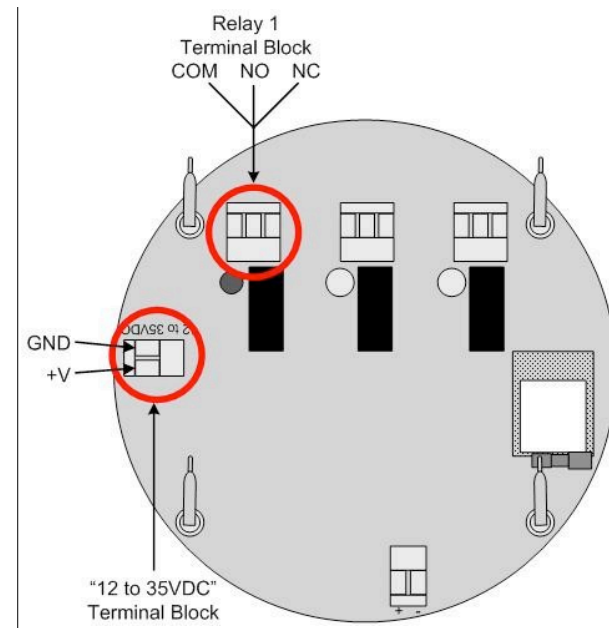

Relay 2 (High Alarm) Wiring Configurations

1. After the Relay 1 Wiring Configurations have been completed (see previous section), locate the Relay 2 terminal block on the back of the Terminal Board.
2. Bring the two conductor cables from the High Alarm to the OI-7530 using the proper certified 3/4" NPT cable gland or conduit fitting.
3. Run the two conductor cables for Relay 2 from the High Alarm through the hub on the OI-7530 Enclosure.
4. Connect a jumper wire (blue) from the terminal labeled "COM" on the Relay 1 Terminal Block to the terminal labeled "COM" on the Relay 2 Terminal Block.
5. Connect the positive wire (red) from the High Alarm to the terminal labeled "NO" on the Relay 2 Terminal Block.
6. Connect the neutral wire (black) from the High Alarm to the terminal labeled "V-" on the internal DC Power Terminal Block.
7. Once the Relay 2 Wiring Configurations are complete, proceed to the next section.

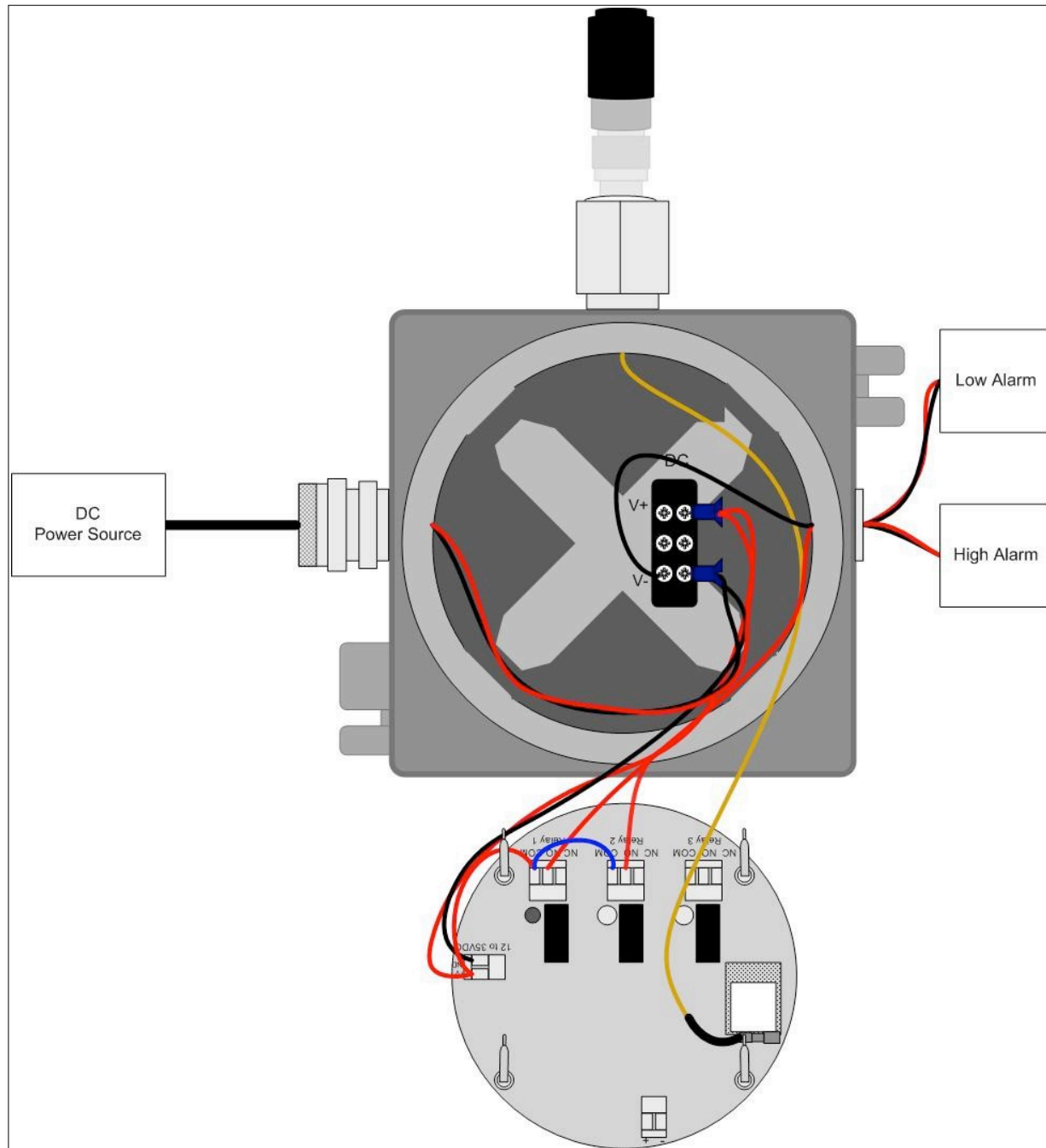
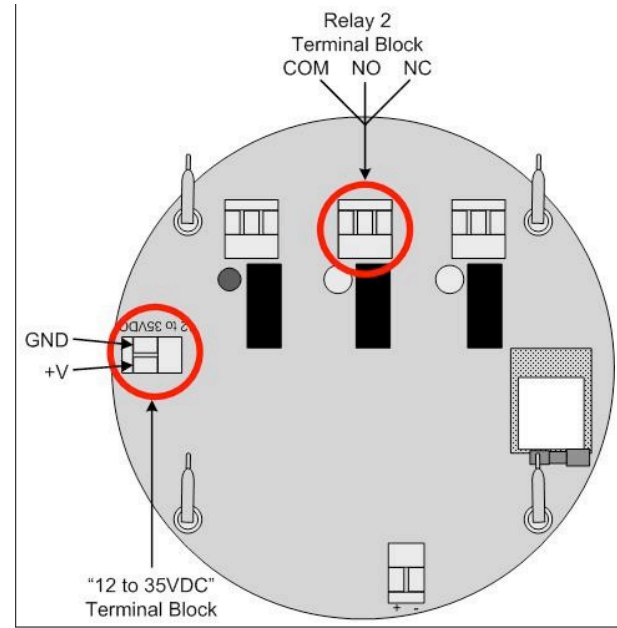

Relay 3 (Danger) Wiring Configurations

1. After the Relay 2 Wiring Configurations have been completed (see previous section), locate the Relay 3 terminal block on the back of the Terminal Board.
2. Bring the two conductor cables from the Danger Alarm to the OI-7530 using the proper certified 3/4" NPT cable gland or conduit fitting.
3. Run the two conductor cables for Relay 3 from the Danger Alarm through the hub on the OI-7530 Enclosure.
4. Connect a jumper wire (blue) from the terminal labeled "COM" on the Relay 2 Terminal Block to the terminal labeled "COM" on the Relay 3 Terminal Block.
5. Connect the positive wire (red) from the Danger Alarm to the terminal labeled "NO" on the Relay 3 Terminal Block.
6. Connect the neutral wire (black) from the Danger Alarm to the terminal labeled "V-" on the internal DC Power Terminal Block.
7. Replace the Control Board and attached components into the enclosure by matching each of the mounting posts to its corresponding receptacle inside the enclosure.

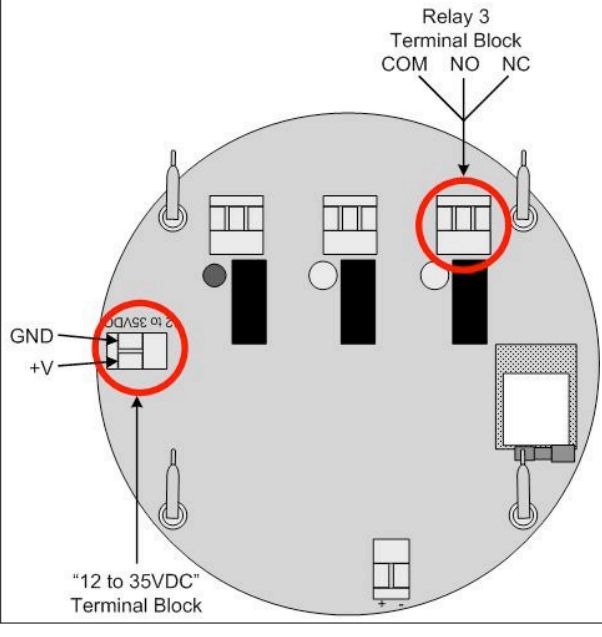

NOTE: When replacing the boards back in the enclosure, be careful not to disturb or remove any of the wires that were just configured.

8. Verify that each mounting post is properly fitted in its corresponding receptacle inside the enclosure.
9. Place the enclosure lid on top of the enclosure base.
10. Rotate the lid until it is tightly screwed in place (approximately 20 rotations).
11. All DC Wiring Configurations are complete. Once power is supplied, the device will be fully functional and ready to operate.

DC Wiring Configurations - Complete Wiring Diagram (power and all three relays connected)

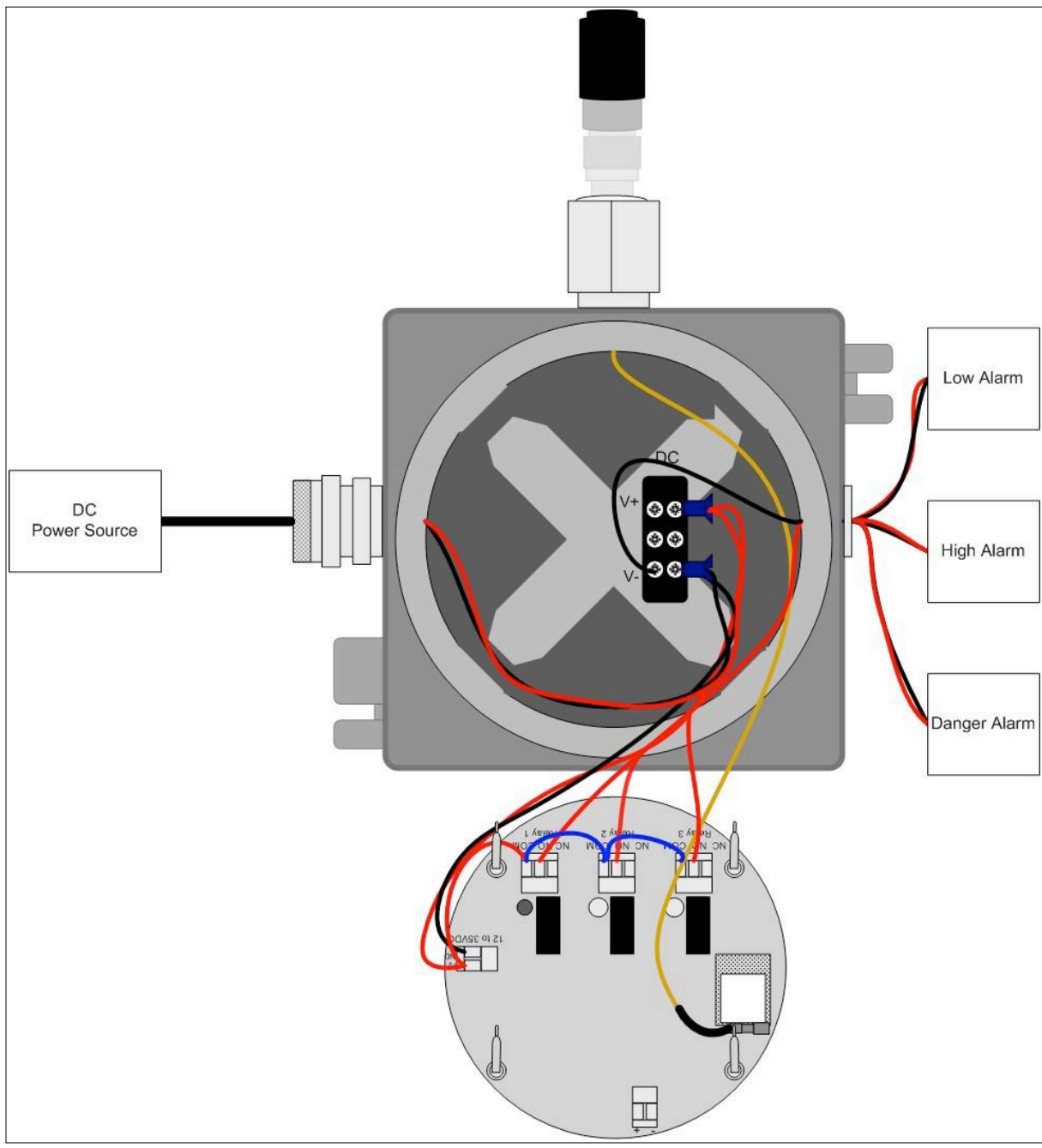

APPENDIX C: OI-7530 Troubleshooting Guide

Fault 1 (F1)

Reason: The top card has lost communication with the digital sensor board (the board potted into the sensor housing).

Solution: Check the connections and/or try new digital sensor board

Applies to: OI-6000-X sensor assemblies

Fault 4 (F4)

Reason: The top card is losing communication to the analog sensor board

Indication: On OI-6000-X units, F4 means that the Analog to Digital Conversion (ADC) on the analog sensor board is not communicating to the digital sensor board.

Solution: Check the orientation of the analog sensor board and/or try a new analog sensor board.

Indication: On the OI-6900-X and OI-6975-X units F4 means the top card is not communicating with the analog sensor board.

Solution: Check the connections from the top card all the way to the analog sensor board. If that does not fix the fault, try replacing the analog sensor board and/or the sensor housing.

Indication: When the sensor element is a Low Power IR sensor the sensor element itself could be the issue. Also, there might not be an issue because sometimes sensor assemblies will show F4 for a few seconds after boot up. This is normal and is due to the boot up of the sensor element itself.

Fault 8 (F8)

Reason: There are two sensors with the same address communicating to the monitor. This could be two different Gen II sensor assemblies, or a Gen I and Gen II sensor assembly. The monitor cannot tell if there are two different Gen I units communicating to the same device with the same address.

Solution: Check all units and make sure they are all using a different addresses.

Fault 9 (F9)

Reason: Radio timeout. This means the monitor has not gotten a communication from the faulting address for over X minutes. X is equal to the radio timeout that is set in the start up menu options. It defaults to 10 minutes.

Solution: Find the sensor assembly and see why it is not communicating. This could be due to a dead battery, broken antenna, bad antenna cable, no antenna, obstacle, weather, etc.

Fault 15 (F15)

This fault is no longer assigned. If "F15" is displayed on a sensor assembly, the firmware should be update

APPENDIX D: Operation of Relays

Relays are offered in certain Otis Instruments devices for the purpose of activating alarms, horns, and other equipment upon the detection of gas.

There are two key terms to remember when using relays.

- Deactivated: refers to a relay is in its normal state
- Activated: refers to a relay in the event of an alarm

“Dry” Contact and “Wet” Contact Relays

In regard to power, there are two types of relays.

1. Dry Contact Relays: This type of relay does not provide power to the equipment attached to it (i.e. if there is a light hooked up to this type of relay, it must be powered by another source).
2. Wet Contact Relays: This type of relay does provide power to the equipment attached to it (i.e. if a light was hooked up to this type of relay, it would be powered by the relay). When using a Wet Contact Relay, power should run through the “COMM” terminal to the end equipment.

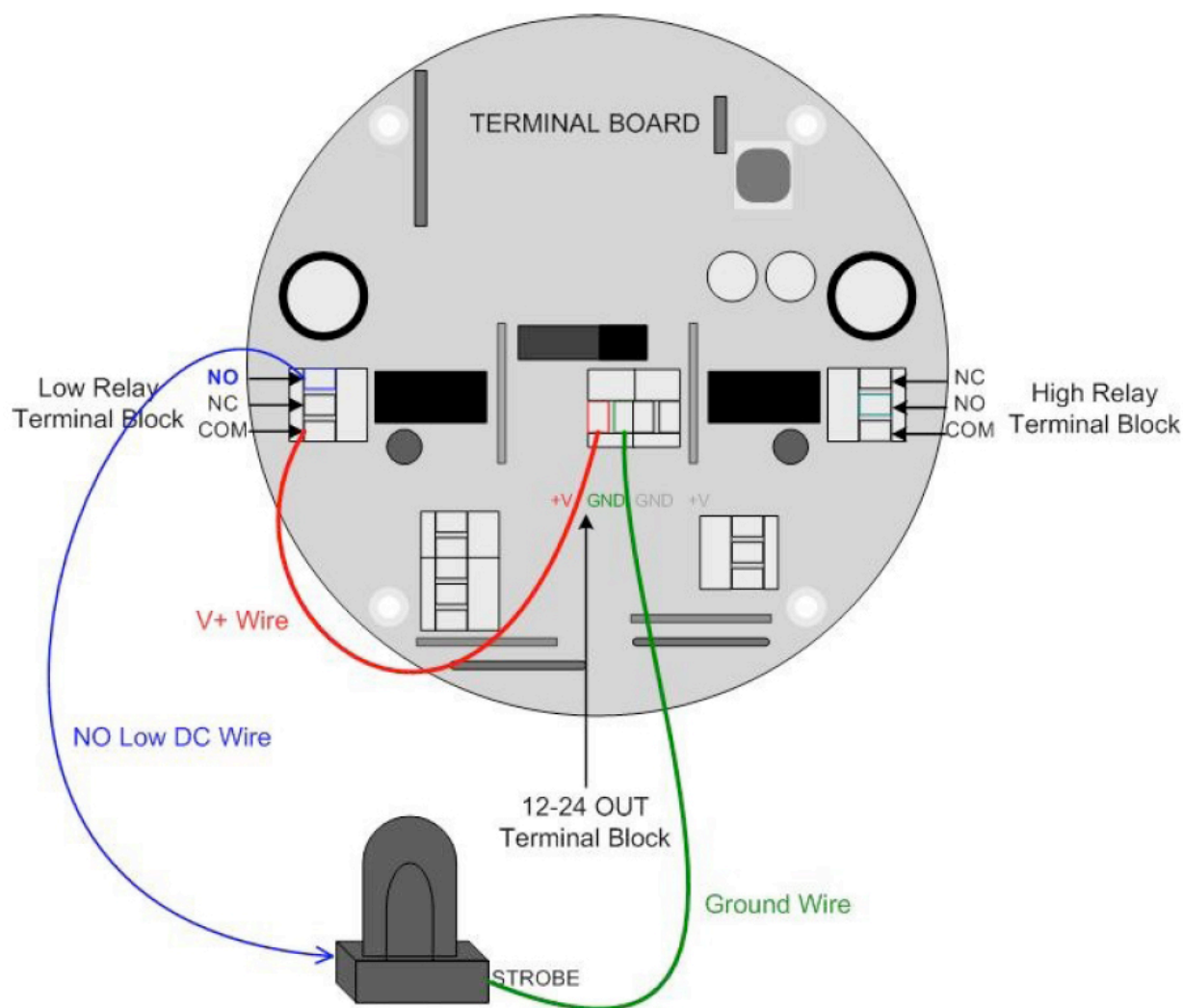

Drawing 1: "Dry" Contact Relay Configured as a "Wet" Contact

Both the Wet Contact and Dry Contact Relays can be further broken into their connection type.

Normally Open and Normally Closed Relays

There are two different connection types used in Otis Instruments products:

1. Normally Open (NO): when the relay is deactivated, it is “open”. When a signal is received to activate the relay, the connection will “close”—providing a closed circuit. This will allow whatever device that is connected (strobe, horn, etc) to be activated (turned on) when a signal is sent to the relay to activate it. This is the most common configuration. It can be used to set off an alarm or strobe light to indicate that there is an issue.
2. Normally Closed (NC): when the relay is deactivated, it is “closed”. When a signal is received to activate the relay, the connection will “open”—providing an open circuit. This will allow whatever device that is connected to the relay to be deactivated (turned off) when a signal is sent to the relay to activate it. Ex: If there was a powered light connected to this relay to indicate that the system was up and running, when the signal to activate the relay is sent the light will turn off. Therefore, the user is made aware that there is an issue.

If a light was connected in the NO configuration with the default setting (not failsafe), then the light would not turn on in the event of a power loss. If the light was used in the NC configuration, the light would stay lit (provided the light is powered by a different source).

Failsafe Relays

There is an option in Otis Instruments devices to set the relays as “failsafe” or “not failsafe”. This refers to what type of signal is being sent through the relay, which can be a “high” or a “low” (on or off). The default setting is “not failsafe”, which means that the devices will operate as described above.

Failsafe mode was introduced to be able to show a change in state (or alarm) in the event of a power loss. If the NO configuration was used in failsafe mode, it could indicate that there was a power loss by turning off of a light.

If the “failsafe” setting is used, the relays will behave as follows:

1. Normally Open (NO): when the relay is deactivated, it is “closed”. When a signal is received to activate the relay, the connection will “open”—leaving the circuit open. This means that if a light was configured to this connection in failsafe mode, it would be powered on until the relay activated—then the light would go out. This can be used to alert the user of an issue.
2. Normally Closed (NC): when the relay is deactivated, it is “open”. When a signal is received to activate the relay, the connection will “close”—providing an closed circuit. For instance, this configuration can be used to set off an alarm or strobe light to indicate that there is an issue.

If a light was connected in the NO configuration with the failsafe setting, then the light would not stay lit in the event of a power loss (provided the light has a separate power source). If the light was used in the NC configuration, then the light would turn on (provided the light has a separate power source).

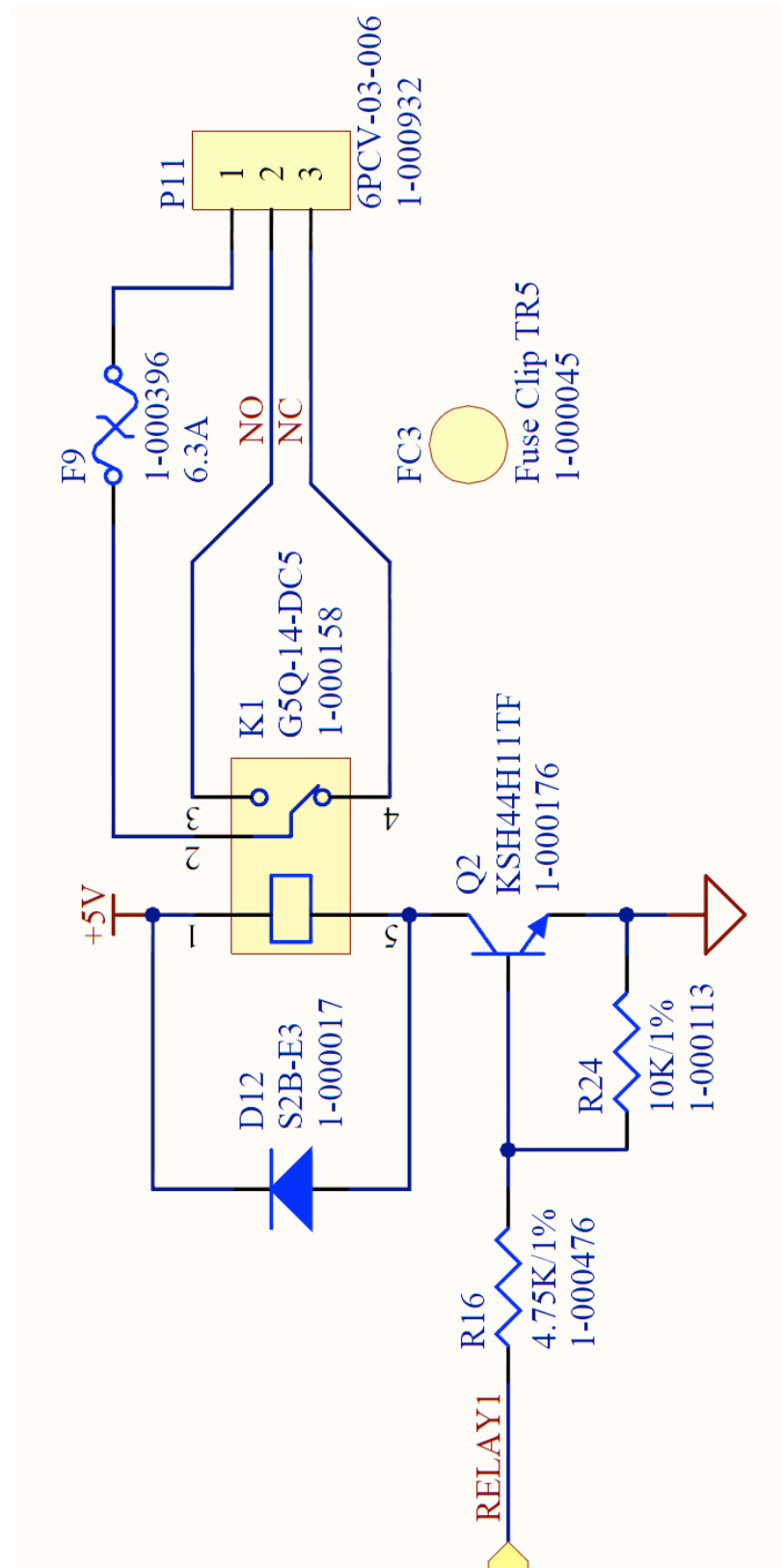

Drawing 2: Schematic of Relay Circuit

Specifications

| | |
|---------------------------------|--|
| Supply Voltage: | 12-35 VDC or 120/240 Volts AC |
| Temperature: | -30 to 70° C |
| Channels: | 32 channels w/ individually configurable set-points |
| Relays: | Three dry-contact (5 Amp) w/ 4 Amp fuses |
| Radio Options: | · 2.4 GHz ISM, 100mW, 3 miles LOS · 900 MHz (expected release: 1H 2011) |
| Antennas: | Solid black – 900 MHz (domestic) Yellow tip – 2.4 GHz (international) |
| RF Connection: | Class I, Div. 1; External N Female connector |
| Enclosure Certification: | Class I, Div. 1 |
| Warranty: | Hardware: One year (Limited) |

Warranty Statement for The Gen II WireFree Relay OI-7530

Hardware

Otis Instruments, Inc. (Manufacturer) warrants its products to be free of defects in workmanship and materials—under normal use and service—from the date of purchase from the manufacturer or from the product's authorized reseller. The hardware for this device is under a one year limited warranty.

The manufacturer is not liable (under this warranty) if its testing and examination disclose that the alleged defect in the product does not exist or was caused by the purchaser's (or any third party's) misuse, neglect, or improper installation, testing or calibrations. Any unauthorized attempt to repair or modify the product, or any other cause of damage beyond the range of the intended use, including damage by fire, lightening, water damage or other hazard, voids liability of the manufacturer.

In the event that a product should fail to perform up manufacturer specifications during the applicable warranty period, contact the product's authorized reseller or return the product directly to the manufacturer with a Return Material Authorization (RMA). This number will be assigned upon contacting customer service at 979.776.7700 or Otis@otisinstruments.com. The manufacturer will--at its option and expense--repair or replace the product, or deliver an equivalent product or part to the purchaser at no additional charge.

Any replaced or repaired product or part has either a 90-day warranty or the remainder of the initial warranty period (whichever is longer).



Otis Instruments, Inc.

2200 E. Villa Maria Dr.

Bryan, TX 77802

Service Department: 903.566.1300

Corporate Office: 979.776.7700

service@otisinstruments.com

www.otisinstruments.com